

Power CUT Series



GeKaMac®



PoWer CUT 155 Users Manual

Please Read and Understand This Manual
Before Operating The Welding Machine

www.gedikwelding.com

Introduction	2
Description	2
PoWer CUT 155 torches	3
CS - Original spare parts	3
Usage limits (IEC 60974-1)	3
Technical characteristics	4
Opening the packaging	4
How to lift up the machine	4
Plasma cutting	4
Installation	5
Connection to the electrical supply	5
Usage norms	5
Connection of plasma torch and ground wire	7
Connection of compressed air	8
Switching on the equipment and initial screens	9
Displaying the software version installed	9
Sequence of operations to perform before cutting	10
Energy saving	10
Configuring the torch for manual cutting	11
Using the torch for manual cutting	12
Configuring the torch for automatic cutting	15
Using the torch for automatic cutting	19
Automatic CNC cutting tables	21
Maintenance	40
Possible problems and remedies	41
Error condition	41
Main troubleshooting table	42
Changing the digital interface board	43
Common cutting defects	44
Meaning of graphic symbols on machine	45
Wiring diagram	46

Introduction

Thank you for buying our product.

In order to get the best performance out of the machine and ensure the maximum lifespan of its parts, the use and maintenance instructions contained in this manual must be read and strictly complied with, as well as **the safety instructions contained in the relevant folder**. If repairs to the machine are required, we recommend that our clients contact our service centre workshops, as they have the necessary equipment and personnel that are specifically trained and constantly updated. All our machines and equipment are constantly developed and so changes may be made in terms of their construction and features.

Description

After significant investments and resources put into research, these inverter generators, with new technology torches, make a significant increase in the quality and speed of the cutting process possible. This quality takes the form of precise outlines, edges without burrs, a limited thermally altered zone, and a sufficiently square edge.

Our **PoWer CUT 155** systems are an efficient solution when it comes to cutting any metal and perforated plates. The inverter's electronic control, precision, and flexibility make it possible to determine the most correct parameters, in order to ensure high quality cutting specifically related to the thickness and type of material to be cut.

Thanks to the new **PoWer CUT 155** torches for manual cutting, and **PoWer CUT 155** for automated CNC cutting, the **PoWer CUT 155** models make it possible to make cuts without using high frequencies to ignite the arc, thereby reducing disturbance of the external environment.

Our powerful **PoWer CUT 155** generators, with a professional, high flow rate, air system, guarantee perfect cuts.

The salient technical characteristics that are common to all machines, are as follows:

- Three-phase power supply.
- Stability of cutting parameters, despite power supply fluctuations.
- Automatically resetting protective devices against under voltages and overvoltages on the electricity mains.
- Trip switches to protect against overloading.
- Reduced energy consumption.
- Digital control for arc parameters for excellent cut quality.
- Professional, high flow rate air system.
- Torch with pilot arc.
- Centralised torch connection.
- Electrical protective device on the torch to guarantee the operator's safety.
- Capacity to cut meshes and perforated plates.
- Capacity for contact cutting with currents less than 50A, without using slides or other spacers.
- Air filter and regulator unit with automatic expulsion of impurities.
- Digital pressure gauge for measuring the air pressure.
- Innovative, functional design, with an inclined front panel, making it clearly visible from any angle, for easy reading and setting of parameters.
- Metal loadbearing structure, with front panels on impact-resistant fibre, and commands protected against accidental impacts.
- Strong handle built into the frame.

- IP23S protection level and electronic parts protected against dust, thanks to the innovative “tunnel” ventilation system, which allows the unit to be used in the most problematic working environments.
- Smart Start Transfer function, for better control over the initial cutting phase. Innovative electronic circuit that allows optimum, gradual transferring of the pilot arc to the main arc, while the cutting arc is being ignited, ensuring immediate stability of the plasma flow and longer duration of consumables used for the torch.
- Smart End Cutting function, for better control over the final cutting phase. Once cutting has been completed, the current reaches an optimum value, which allows definitive detachment of the pieces. In addition to reducing the noise when cutting ends, this device means that the operator does not have to separate the pieces manually, thereby ruining the final portion of the cut surface.

PoWer CUT 155 torches

The **PoWer CUT 155** torches, used with the **PoWer CUT 155** machines, are the result of research done over the last decade, aimed at improving the performance of the plasma beam, in order to increase control and thermal energy.

More specifically, the **PoWer CUT 155** torches are characterised by High Performance Cutting (HPC) technology, which makes it possible to increase the quantity and speed of the air, enhance concentration of the plasma beam, and stabilise the cutting arc, which allows:

- High cutting speeds.
 - Optimum quality and cleanliness of the cutting surfaces.
 - High concentration of the Plasma beam.
 - Absence of burrs.
 - Reduction of the thermally altered zone.
 - Longer lifespan for consumables.
 - Piercing of plating more quickly.
 - Gouging to remove material with the help of a plasma beam.
- All **PoWer CUT 155** torches are fitted with a coaxial cable that ensures great flexibility, combined with significant strength and resistance to crushing.

The High Performance Cutting - HPC technology, makes it possible to generate radial and vortex gas flows about the arc's axis, thereby creating a Plasma beam at very high temperature that pierces and vaporises the surface being worked more efficiently.

This technology also makes it possible to avoid double arcs from forming - two arcs in series between the cathode and the workpiece's surfaces - which is mainly responsible for damaging the nozzle and instability of the arc - ensuring execution of very high quality cuts, along with longer duration of consumables.

Vortex gas flows and collimation of the beam

The new **PoWer CUT 155** torches, equipped with **High Performance Cutting**, increase the density of the Plasma beam's energy, while reducing the width of the arc's area of action, producing a narrower cut path, at less of an angle, easily removing molten material. This results in a better quality cut that has neat surrounding without burrs, a limited extent of the thermally altered zone, and a sufficiently squared edge.

The main advantages include:

- Better cut quality.
- Higher cutting speed.
- Narrower cuts.
- Long duration of consumables.

CS - Original spare parts

CS is our guarantee mark for all PlasmaTECH consumables. The **CS** mark is to be found on all original spare parts for PoWer CUT 155 torches, used for the **PoWer CUT 155** machines.

The presence of the **CS** mark on all consumables, is a guarantee for those buying a cutting machine, that the machine's declared performance levels will be delivered.

The geometric shapes, quality of the materials used, and precision of the machining and coupling of the same, resulting from years of experience, form the basis for developing the **PoWer CUT 155** torches, and use of the same with our cutting generators. We highly recommend the use of original spare parts marked **CS**. In addition to compromising optimum function of the machine, using pirate parts could result in overheating and fluctuations in electrical voltages, which is turn can cause:

- Overheating and damaging of the torch.
- Malfunctions and faults on the generator.
- Worsening of cut quality.
- Lessening of machine safety.

In light of the above, using any parts other than **CS** not only causes the warranty on the machine to be null and void, but it also means that GeKaMac PlasmaTECH cannot be held responsible in case of any accidents.

Usage limits (IEC 60974-1)

The use of plasma equipment for cutting is typically discontinuous as it consists of periods of effective operation (cutting) and rest periods (while the piece is being positioned, etc.). The size of the equipment is suitable for safe use of max. nominal current I_2 for a working time that is 30% of the total time of use. The regulations in effect stipulate that 10 minutes is the maximum total time of use. For the work cycle, 30% of that time is considered. Any excess of the permitted work cycle triggers a thermal circuit breaker which protects the internal components of the equipment against dangerous overheating. Activation of thermal protection is signaled by “t° C” flashing on control panel display. After a few minutes the trip switch resets itself automatically and the cutting equipment is once again ready for use. This equipment is built to have a protection level of IP 23 S, which means:

- That it is protected against the penetration of solid foreign bodies with diameters in excess of \varnothing 12 mm.
- That it is protected against water spray hitting the surface with an angle of incidence up to 60°.
- That the equipment has been tested for withstanding harmful effects due to water getting in when the moving parts on the equipment are moving.

Technical characteristics

Pure cutting power - of the entire range, the PoWer Cut 155 model provides the highest performance. The powerful, compact PoWer Cut 155 model is a plasma unit that satisfies the needs of medium / light metalwork most fully.

The unit comes with a display for digital control of all cutting parameters. Smart Start Transfer and Smart End Cutting function, for better control over the initial and final cutting phases. The cuts are always precise and ensure high cutting standards in any situation.



High quality and cutting speed thanks to the PoWer Cut 155 torch, with (HPC) High Performance Cutting technology, which ensures a concentrated, powerful plasma beam.

Further particular features of this machine include:

- with torch with (HPC) High Performance Cutting technology and coaxial cable.
- Powerful, compact and light-weight, only 48 kg.
- High productivity thanks to high cutting quality and speed.
- Lower operating costs due to the long lifespan of consumables.
- "Energy Saving" function that starts ventilation of the generator only when necessary.
- Electrical protective device on the torch to guarantee the operator's safety.

The technical data for this equipment is summarized in the table 1.

Table 1

Model	PoWer Cut 155	
Three-phase power supply 50/60 Hz	V	400
Mains supply: Z_{max}	Ω	0,017
Power input @ I_2 Max	kVA	27,5
Delayed fuse (I_2 @ 100%)	A	30
Power factor / $\cos\phi$		0,89/0,99
Efficiency degree	η	86%
Open circuit voltage (peak)	V	320
Current range	A	25 ÷ 150
Duty cycle @ 100% (40°C)	A	100
Duty cycle @ 60% (40°C)	A	120
Duty cycle @ 30% (40°C)	A	150
Cutting capacity recommended	mm	45
maximum	mm	50
severance	mm	60
piercing	mm	25
Type of machine intake air/gas	AIR - Clean, dry, oil-free for ISO 8573-1 Class 1.2.2 N2 - 99.95%	
Air pressure (cutting mode)	5,0 ÷ 6,0	
Air flow (cutting mode)	360 ÷ 410	
Standards	IEC 60974-1 IEC 60974-7 IEC 60974-10 CE 	
Protection class	IP 23 S	
Insulation class	F	
Dimensions 	mm	730-515-290
Weight	kg	48

WARNING: This equipment complies with EN/IEC 61000-3-12 provided that the maximum permissible system impedance Z_{max} is less than or equal to 0,017 Ω at the interface point between the user's supply and the public system. It is the responsibility of the installer or user of the equipment to ensure, by consultation with the distribution network operator if necessary, that the equipment is connected only to a supply with maximum permissible system impedance Z_{max} less than or equal to 0,017 Ω .

This system, tested according to EN/IEC 61000-3-3, meets the requirements of EN/IEC 61000-3-11.

Opening the packaging

The standard composition of this plasma cutting system is made up of:

- Plasma cutting units.
- Plasma torch with centralised connection and initial supply spare parts kit.
- Ground cable.
- Trolley for transportation (optional).

On receipt of the unit, perform the following operations:

- Remove the plasma cutting unit and all relative accessories and components from the packaging.
- Check that the plasma cutting unit is in good condition. If it is not, inform your dealer immediately.
- Make sure that all the ventilation louvers are open and that the airflow is not obstructed.

How to lift up the machine

This equipment has a handle specifically for carrying the machine by hand.

NOTE: These hoisting and transportation devices conform to European standards. Do not use other hoisting and transportation systems.

Plasma cutting

The cutting system used by this equipment is a low current system that uses compressed air as its plasma equipment as well as for cooling. The air normally used is a mixture of 79% nitrogen and 21% oxygen. These two biatomic gasses have almost identical enthalpy and form a highly energetic blend. The low current also makes it possible to use torches with a low air capacity and moderate cutting speed, that are more suitable for manual procedures.

CUTTING PARAMETERS

In analyzing the parameters that characterize manual plasma cutting it is necessary to note that they depend on the material to be cut, its thickness and the skill of the operator in following the cutting line. Optimum speed depends largely on the skill of the operator and amount of material to be cut and is achieved when the fused material flows through the groove and is not projected in the direction of the torch. If the latter occurs, cutting speed has to be reduced.

The parameters that affect cutting are:

- **Electric power.** Any increase in electric power will permit higher cutting speed and greater thickness of the material to be cut
- **Compressed air capacity.** Increasing the air capacity enables cutting thicker material and ensures better quality at any thickness
- **Distance between the nozzle and workpiece.** The appearance of the cut and wear of the torch's working parts, depend on the correct distance between the nozzle and the workpiece.

NOTE: The width of the cut path is equal to about twice the diameter of the hole in the nozzle.

Respect of the above recommendations ensures greatly reduced thermal alterations of the material due to cutting, that are in any case always fewer than those caused by oxygen torches. The thermally altered zone is in any case smaller than the zone on which the weld is effective, so that in welding pieces that have been cut by plasma it is not necessary to perform any cleaning or grinding operations.

Installation

The place where the equipment is installed should be selected with care so as to ensure satisfactory, safe use.

The user is responsible for installation and use of the equipment according to the instructions provided by the manufacturer in this manual.

Temperatures must be between -25 °C e +55 °C. during transportation and/or storage in stores.

Before installing the equipment the user should take into consideration any possible electromagnetic problems in the work area.

In particular, we recommend that the equipment not be installed in the vicinity of:

- Signalling, control and telephone cables.
- Radiotelevision transmitters and receivers.
- Computers or controlling and measuring instrument.
- Safety and protection devices.

If the operator wears a pacemaker, hearing aid or other similar device, he should consult his doctor before approaching the equipment while it is running. The environment where the equipment is installed must conform with the degree of protection of the chassis that is IP 23 S (IEC publication 60529). The system is capable of working in environments where working conditions are particularly hard.

This equipment cools water by forced circulation of air and must therefore be positioned in such a way that the air can easily be drawn in and expelled through the openings in the chassis.

Connection to the electrical supply

Connection of the machine to the user line (electrical current) must be performed by qualified personnel.

Before connecting the cutting equipment to the mains supply, check that the data on the machine plate correspond to the supply voltage and frequency and its main switch is on the "0" position.

This system has been designed for nominal voltage 400 V - 50/60 Hz.

The connection to the supply, should be made with four core cable which is supplied with the machine, connecting:

- Three wires the supply.
- The fourth one, YELLOW-GREEN, to ground.

Connect a suitable plug (3p+e) of proper capacity to the mains cable and fix to a socket fitted with fuses or automatic switch: the proper ground terminal must be connected to the ground connector (yellow-green) of the main supply.

Table 2 shows the capacity values that are recommended for fuses in the line with delays.

Table 2

Model		PoWer Cut 155
Power input @ I ₂ Max	kVA	27,5
Delayed fuse (I ₂ @ 100%)	A	30
Duty cycle @ 30% (40°C)	A	150
Mains supply connection cable		
Length	m	4
Section	mm ²	6
Ground cable		
Length	m	4
Section	mm ²	25

NOTE: If extensions of the power supply cable are used, they must be of adequate cross section and never inferior to that of the cable supplied.

Usage norms

COMMAND AND CONTROL DEVICES (Fig. A)

- Pos. 1** Control panel (Fig. B).
Pos. 2 Snap-in connector for ground line.
Pos. 3 Centralised torch attachment.
Pos. 4 Connector, 14 pole, for CNC control interface (optional extra).
Pos. 5 Filter and cutting air pressure regulator. The air filter automatically expels impurities.
Pos. 6 Fast coupling to connect compressed air tube.
Pos. 7 Cutting machine power supply cable.
Pos. 8 Power supply switch.
Pos. 9 Robomat1 interface (optional).

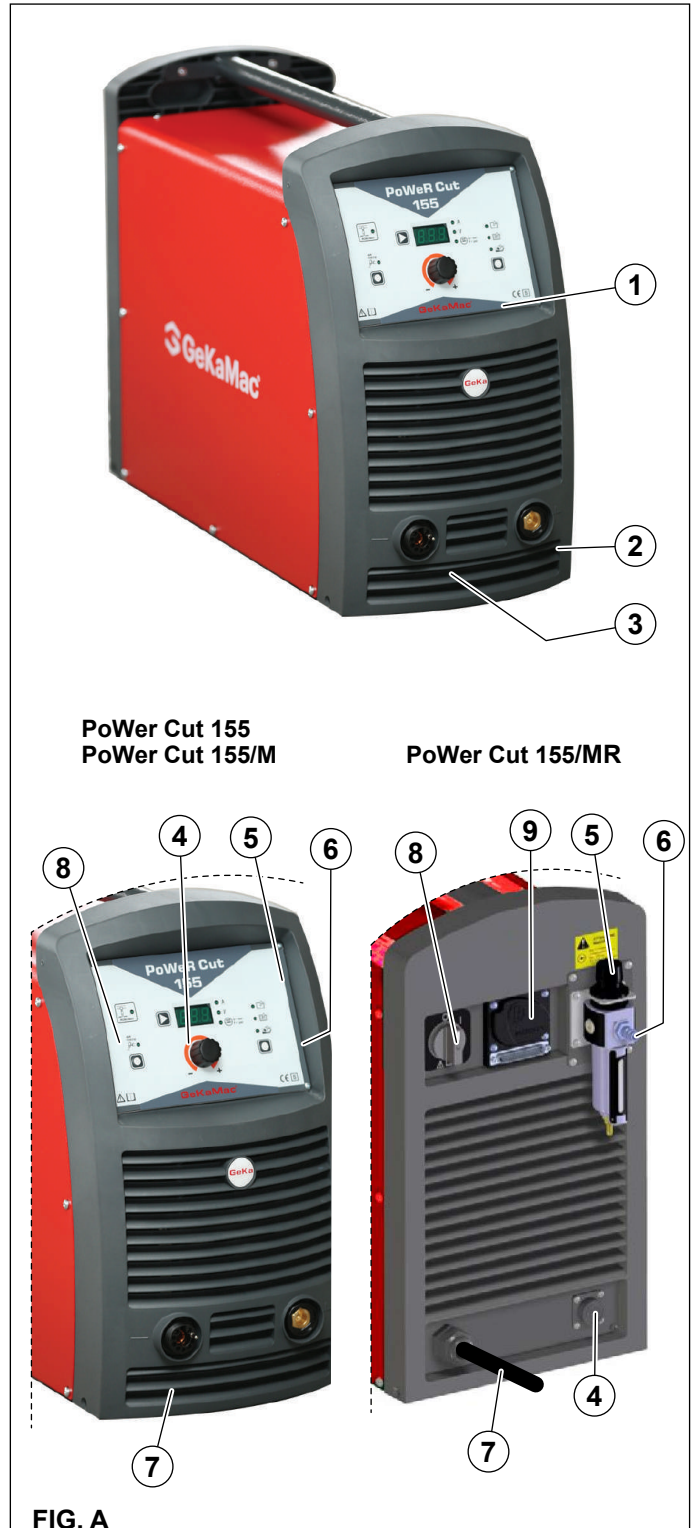

CONTROL PANEL (Fig. B)

Pos. 1 Cutting parameter regulating knob (current, voltage and air pressure), according to the LED that is on.





Pos. 2 Compressed air button.

When this button is pushed and released, the cutting air valve opens, allowing the operator to regulate the compressed air pressure, using the filter / regulator knob (Pos. 5, Fig. A) located on the back panel.

The display shows the real-time cutting air pressure (in bar or psi).

If the air pressure value shown in the display flashes, this means that it is outside the optimum range for the cutting mode selected.

Rotate the filter / regulator knob until the display shows the optimum pressure, as indicated in the table below. The pressure value is displayed continuously, without flashing.

Cutting mode	Optimum pressure	Minimum / Maximum pressure alarm
 	5,5 bar 80 psi	4,5÷6,5 bar 65÷94 psi
	3,7 bar 54 psi	3,0÷4,5 bar 44÷65 psi

The operation is ended manually by pushing and then releasing the key (or automatically after a delay of 10 seconds).

Pos. 3 RoboMAT LED.

This switches on when the equipment is connected to the "RoboMAT 1" analogue / digital robot interface and this is powered by the automatic system connected up.

NOTE: The generator automatically recognises the robot interface connection.

Pos. 4 Display selection key.

Used for cyclical selection of the following 3 cutting parameters, according to the corresponding LED switched on:

CUTTING CURRENT (variable from 25A to 150A).



The cutting current can be set beforehand by rotating the parameter setting knob.

CUTTING VOLTAGE - The display shows the cutting voltage. LED "V" is on.



AIR PRESSURE - When this LED is switched in this means that the DISPLAY is showing the real-time AIR PRESSURE (in bars) measured at the equipment intake (adjustable value). You can change the unit of measure of air pressure between bar and psi by doing the following:

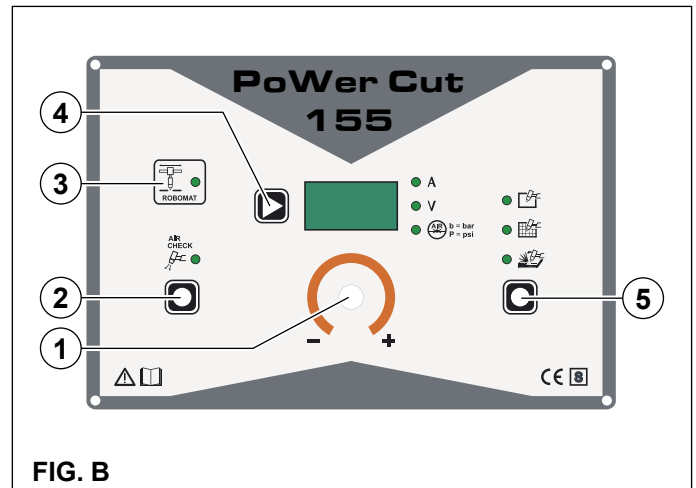

- Hold the display selection key down for about 3 seconds.
- Rotate the parameter regulating knob, to change to the required unit of measurement (bar or psi).
- Confirm the choice made, by pushing the display selection key.

NOTE: When the LED for the CUTTING CURRENT, the CUTTING VOLTAGE, or the AIR PRESSURE flashes, this means that during the HOLD function, the display shows the last value read at which the operator was cutting. When the LED stays on, this means that the display is showing the preset value for the CUTTING CURRENT, or the real value measured for the CUTTING CURRENT, the CUTTING VOLTAGE, or the AIR PRESSURE.





Pos. 5 Cutting mode selection button.

This can be used to select one of the 3 cutting modes, as indicated by the corresponding LED that switches on:

- Solid material mode (when the torch button is pushed, when the operator goes out of the workpiece during cutting, the arc switches off automatically). 
- Mesh material mode (when the torch button is pushed, when the operator goes out of the workpiece during cutting, the pilot arc ignites again automatically, to allow cutting to continue). 
- Gouging mode to remove material with the help of a plasma beam. 

NOTE: Each time the cutting mode is changed, the display shows the cutting pressure, to allow the operator to check that this value is correct.

Cutting mode	Optimum pressure
 	5,5 bar 80 psi
	3,7 bar 54 psi

Connection of plasma torch and ground wire

IMPORTANT: Before performing any operation regarding connection of the torch and ground wire, disconnect the power to the system.

IMPORTANT: Do not connect to the Plasma equipment any other torch different from the standard supplied ones; the utilisation of other non suitable torches might be dangerous for the operator.

To obtain elevated cutting quality, the torch must transform the power generated by the machine into a high energy density plasma jet, so that it can efficiently melt metal and guarantee sufficient strength to remove the melted part from the cutting zone, impeding the formation of burrs. The torch is this a fundamental, indispensable component of the plasma cutting machine.

The standard supplied Plasma torch has special GeKaMac electrical connections in the central adaptor. Before fitting a new equipment, make sure that the torch central adaptor electrical connections are matching the ones of the Plasma equipment.

To assemble the plasma torch, proceed as follows:

- Screw the male connection on the plasma torch clockwise all the way into the corresponding centralised female connection, located on the front of the plant.
- Align the male polarisation pin (n° 8) with the corresponding pin (n° 8) on the plasma torch's male coupling (Fig. C).

To disconnect the torch, proceed in the reverse order.

To assemble the earth cable, proceed as follows:

- Connect the earth cable to the rapid coupling on the positive pole as indicated in figure C.
- The earth cable must be connected to the workpiece to be cut, using the relevant terminal, so that the workpiece is effectively earthed along with the cutting bench.

To connect the earth cable correctly:

- Make sure that the metal-to-metal contact between the earth clamp and the steel plate is adequate. Remove any rust, dirt, paint, coating or other debris, in order to ensure correct contact between the generator and the steel plate.
- In order to achieve an excellent quality cut, connect the earth clamp as close as possible to the area to be cut.
- Do not connect the earth clamp to the piece of material to be removed.





Pressure	Nozzle						Pressure	Nozzle	
	160 A	125 A	105 A	85 A	65 A	45 A		160 A	105-125 A
4,5 bar 65 psi	315 l/min 667 cfh	310 l/min 655 cfh	305 l/min 645 cfh	300 l/min 635 cfh	265 l/min 560 cfh	235 l/min 500 cfh	3,0 bar 44 psi	250 l/min 530 cfh	225 l/min 475 cfh
5,0 bar 72 psi	345 l/min 730 cfh	340 l/min 720 cfh	335 l/min 710 cfh	330 l/min 700 cfh	285 l/min 605 cfh	250 l/min 530 cfh	3,5 bar 51 psi	285 l/min 605 cfh	255 l/min 540 cfh
5,5 bar 80 psi	375 l/min 795 cfh	365 l/min 775 cfh	360 l/min 760 cfh	355 l/min 750 cfh	310 l/min 655 cfh	275 l/min 580 cfh	4,0 bar 59 psi	315 l/min 667 cfh	285 l/min 605 cfh
6,0 bar 87 psi	405 l/min 860 cfh	395 l/min 835 cfh	390 l/min 825 cfh	385 l/min 815 cfh	335 l/min 710 cfh	295 l/min 625 cfh	4,5 bar 65 psi	350 l/min 740 cfh	315 l/min 665 cfh

Connection of compressed air

Connect the compressed air hose to the rapid coupling (Fig. D). Use a compressed air hose with a minimum internal diameter of 8 mm.

Make sure that the gas feed pressure does not exceed 8,6 bar / 861 kPa. If the pressure is higher than this value, the filter could explode.

The plant must be fed with a constant air flow, with the following characteristics:

Equipment	PoWer CUT 155
Air / gas	AIR - Clean, dry, oil-free for ISO 8573-1 Class 1.2.2 N₂ - 99.95%

Cutting mode	Optimum pressure
	5,5 bar 80 psi
	3,7 bar 54 psi

Having pressed the compressed air button (Pos. 2, Fig. B), set the pressure regulator to obtain the value indicated on the table above, by raising and then rotating the ring nut, as indicated in figure D. Once regulation has been completed, lower the ring nut.

The compressed air consumption in relation to the pressure, the cutting mode, and the nozzle fitted, is shown in table 3.

NOTE: The pressure must be set with the pressure rising, while the air / gas is flowing.

If the quality of the air / gas supply is not good, the cutting speed diminishes, the cut quality worsens, the cuttable thickness diminishes, and the working lifespan of consumables is reduced.

If moisture, oil or other pollutants get into the air line, due to the general compressor, use the additional GeKaMac filtration system, code 427529 (Fig. D) with a filtration grade of 0,01 µinch - 0,25 µm available via GeKaMac distributors (the order code for replacement filters is 427530).

The additional filtration system must be installed between the air / gas supply and the filter located on the generator's back panel. Additional filtration could increase the minimum feed pressure required.

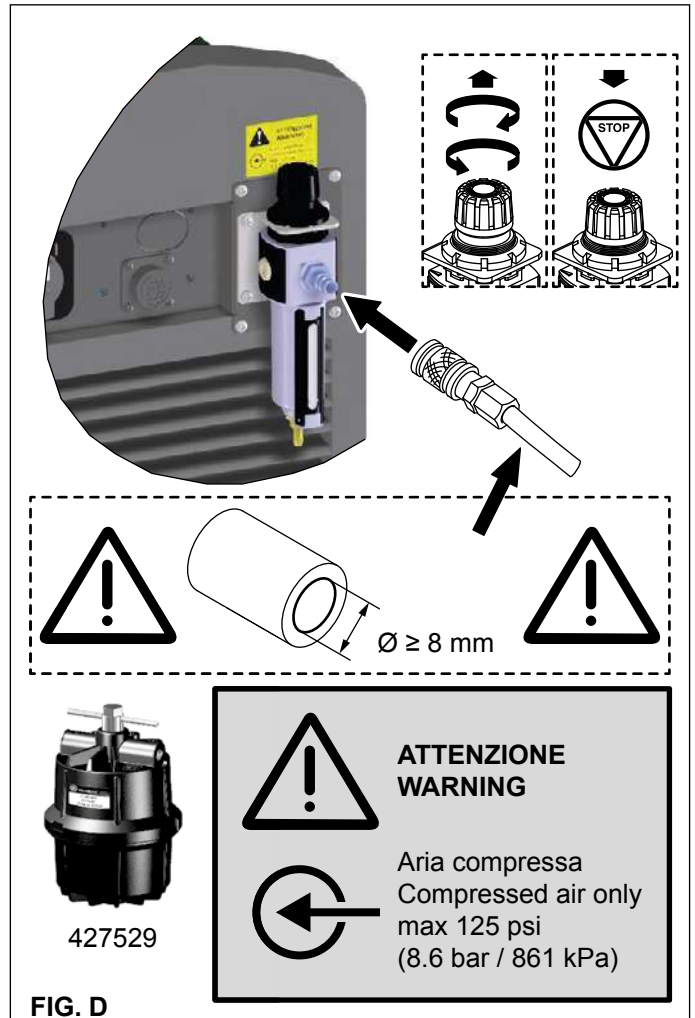
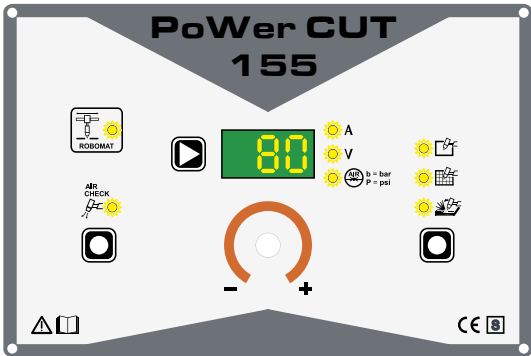

FIG. D

Switching on the equipment and initial screens

- 1) Start the equipment by turning the switch on the rear panel to position I.
- 2) A brief MACHINE CHECK operation is run automatically (all the LEDs switch on and off simultaneously).



- 3) Next the control panel displays the machine's INITIAL SCREEN, and the machine is now ready to cut and the DISPLAY shows the last numerical value set (for example: 80) for the CUTTING CURRENT. Remember that, since the equipment is on stand-by, this value (in Ampere) is not real but is that SET.

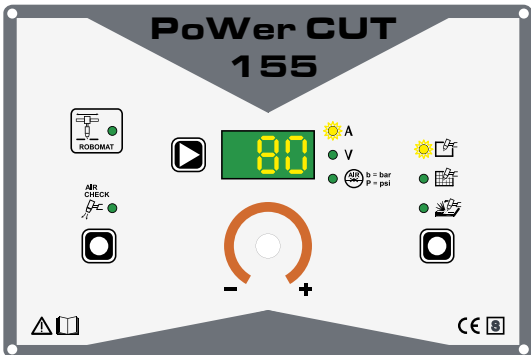

Displaying the software version installed

The PoWer CUT 155 has a digital control with software prepared in the factory in it. This software is subject to continuous evolution and improvement. The software is identified by a specific number that can be viewed on the DISPLAY as follows:

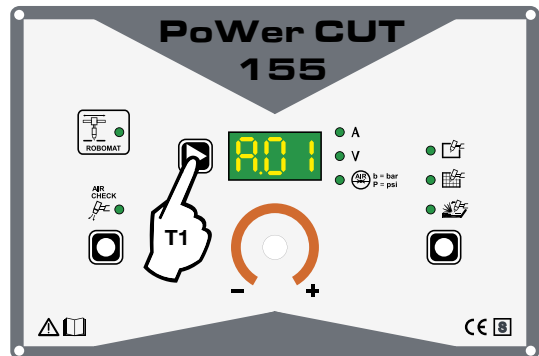

- 1) With the equipment switched off, hold down the DISPLAY SELECTION key (T1).
- 2) Start the equipment by turning the power switch to position I.
- 3) For about 7 seconds the DISPLAY shows the type of software installed (e.g. A.01) where:
 - A indicates the YEAR the software installed was created.
 - 0 indicates the RELEASE of the software installed.
 - 1 indicates the VERSION of the software installed.



Sequence of operations to perform before cutting

IMPORTANT: Before switching on the equipment follow these instructions carefully:

- Make sure the voltage and frequency of the supply network correspond to the data on the rating plate.
 - Make sure all the torch components are correctly installed.
 - Do not point the torch toward yourself or other persons nearby. If switched on accidentally the pilot arc spark would ignite and cause dangerous burns.
- 1) Turn the power switch (Pos. 8, Fig. A) to position I.
 - 2) The equipment has just been started. The equipment's built-in checking device runs a series of programmed tests (see the "Switching on the equipment and initial screens" paragraph) during which the fan motor switches on for a few seconds.
 - 3) By pushing the cutting mode selection key (Pos. 5, Fig. B), according to the corresponding lit LED, the operator can select one of the following operating modes:
 - Solid material mode: when the torch button is pushed, when the operator goes out of the workpiece during cutting, the arc switches off automatically.
 - Mesh material mode: when the torch button is pushed, when the operator goes out of the workpiece during cutting, the pilot arc ignites again automatically, to allow cutting to continue.
 - Gouging mode to remove material with the help of a plasma beam.
 - 4) Press the COMPRESSED AIR TEST Key and check:
 - That air comes out of the torch.
 - If the air pressure value shown in the display flashes, this means that it is outside the optimum range for the cutting mode selected. Rotate the filter / regulator knob until the display shows the optimum pressure, as indicated in the table below. The pressure value is displayed continuously, without flashing.

Cutting mode	Optimum pressure	Minimum / Maximum pressure alarm
	5,5 bar 80 psi	4,5÷6,5 bar 65÷94 psi
	3,7 bar 54 psi	3,0÷4,5 bar 44÷65 psi

- 5) Press the DISPLAY SELECTION key until the DISPLAY shows the current value (CUTTING CURRENT LED switched on and fixed). The value indicated by the DISPLAY is referred to as the PRESET CUTTING CURRENT. Adjust the cutting current using the ENCODER KNOB. Increasing the current makes faster cutting possible or greater thicknesses can be cut at the same speed.
- 6) Move the torch close to the workpiece (Fig. E) and, keeping the shield supported without exerting pressure, push the torch button, thereby igniting the pilot arc and the air supply. Introduce the flame to the workpiece, and begin the cut. Go with the flame to the piece and start cutting. Do not keep the pilot arc in the air, to avoid needless consumption of the electrode and nozzle.
- 7) In special cases if the arc is switched off when the workpiece enters, observe the correct angle of inclination between the torch and the metal (Fig. E). A special control

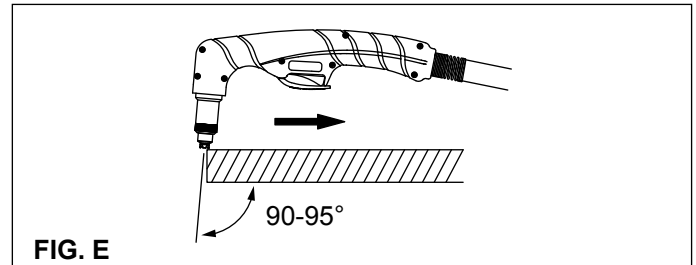

- 8) Cut taking care that the fused material flows through the groove and is not projected in the direction of the torch. If this occurs, reduce cutting speed.
- 9) Upon completion of the cutting operation, the air will continue to issue from the torch for about one minute so as to cool the torch components. Wait for the air to stop flowing before switching the equipment off. During this time, you can also start a new cutting operation. If you have to perform circular cuts, it is advisable to use the special compass supplied on request.

Energy saving

This function manages correct functioning of the fan motor, which is switched on for a predefined time and only when strictly necessary, to guarantee lower energy consumption, that is:

- When the equipment is switched on.
- During the cutting phase.
- On completion of the cutting phase.
- When the thermostat intervenes or after it has been reset.









Configuring the torch for manual cutting

INTRODUCTION

These machines are supplied with the following standard torches for manual cutting:

Other lengths are available by request.

The torches are air cooled, and do not require special cooling. The main nominal characteristics of the torches supplied, are as follows.

 PLASMA	PoWer CUT 155
	PoWer CUT 155 = 6 m (standard) (Other lengths are available by request)
 I ₂ MAX X % AIR	160 A @ 60% (10 min. 40°C)
 V ₂	DC
 AIR	Cutting: 5,0-6,0 bar / 72-87 psi Gouging: 3,5-4,0 bar / 50-58 psi Gas flow @ 160 A: 420 l/min - 890 cfh
 AIR	AIR - Clean, dry, oil-free for ISO 8573-1 Class 1.2.2 N ₂ - 99.95%
 V VOLTAGE CLASS	M
 NO HF	Without HF
	IEC 60974-7

WORKING LIFESPAN OF CONSUMABLES

The following factors affect the frequency with which consumables need to be replaced:

- Thickness of the metal cut.
- Average cut length.
- Air quality (presence of oil, moisture, or other pollutants).
- Execution of piercing of the metal or cutting from the edge.
- Correct piercing depth.
- Cutting done using mesh or solid material cutting mode. Cutting done in mesh mode give rise to more wear of consumables.

Under normal conditions, the nozzle wears out before the other consumables during cutting operations.

CONSUMABLES FOR MANUAL CUTTING

Figure F shows the consumables used for the plasma torches supplied, complete with the GeKaMac order codes.

These torches use shielded consumables and so the point of the torch can be dragged over the metal to be cut.

FITTING CONSUMABLES ON THE TORCH FOR MANUAL CUTTING

WARNING: *changing consumables, check that the machine's main switch is in the O position.*

To use the torch for manual cutting, a complete set of consumables must be fitted, as shown in figure G.

Using the torch for manual cutting

WARNING

Torch with immediate ignition

A plasma arc can cause injuries and burns.

The plasma arc ignites immediately, when the torch button is pushed.

The plasma arc passes through gloves and the skin quickly.

Use appropriate equipment to protect your head, eyes, ears, hands, and body.

Keep away from the tip of the torch.

Do not hold the plate and keep your hands away from the cutting path.

Never point the torch at yourself or other people.

TORCH SAFETY

Torches for manual cutting have a safety guard to prevent involuntary ignition. When you are ready to use the torch, rotate the button's safety guard (towards the tip of the torch) and push the red torch button, as shown in figure H.

SUGGESTIONS FOR USING THE TORCH FOR MANUAL CUTTING

- Drag the torch slightly over the plate to maintain a set cut.
- While cutting, make sure that the sparks come out from the underside of the plate.
- If the sparks come out from the upper side of the plate, move the torch more slowly, or set the output current to a higher value.
- When using SK series torches for manual cutting, keep the nozzle on the torch perpendicular to the plate, so that the nozzle forms a 90-95° angle with the cutting surface. Watch the cutting arc while the torch is cutting.

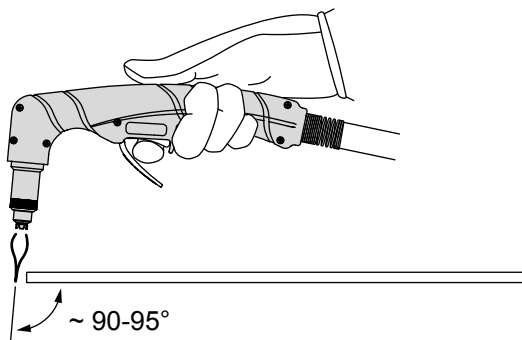

WARNING: *If the torch is ignited when not necessary, the working lifespan of the nozzle and the electrode is reduced.*

For cutting straight lines, using a straight edge as a guide, or the carriage supplied.

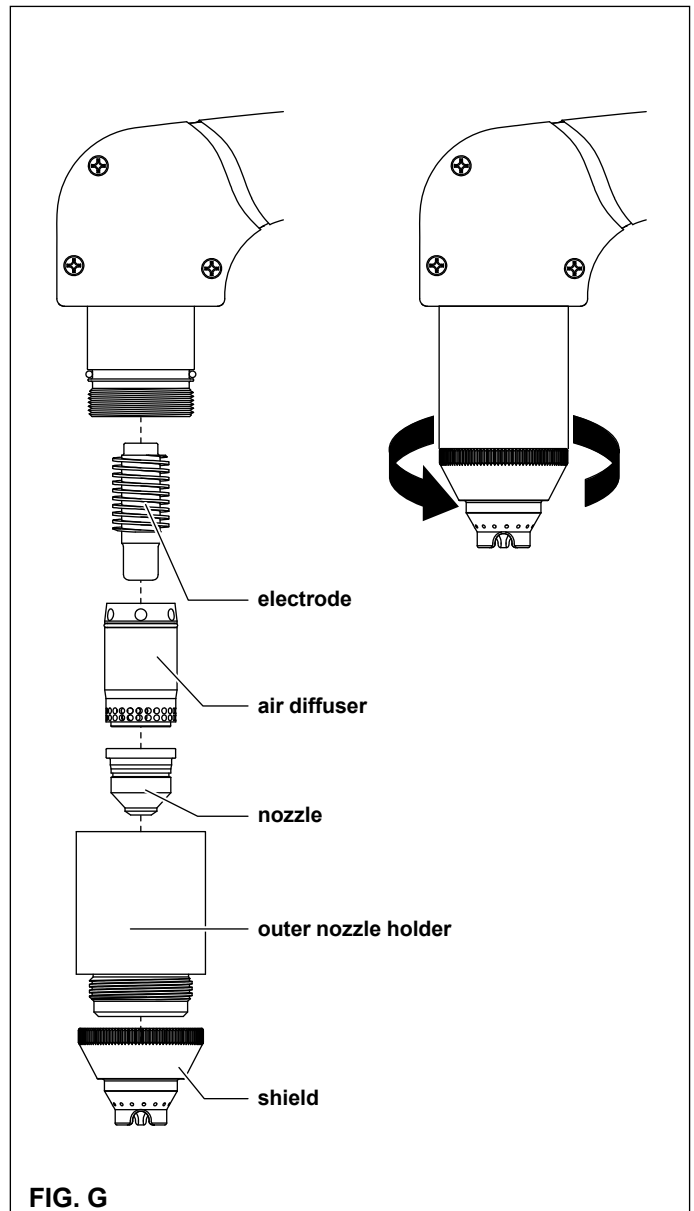
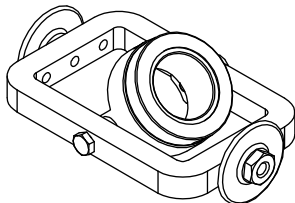

FIG. G

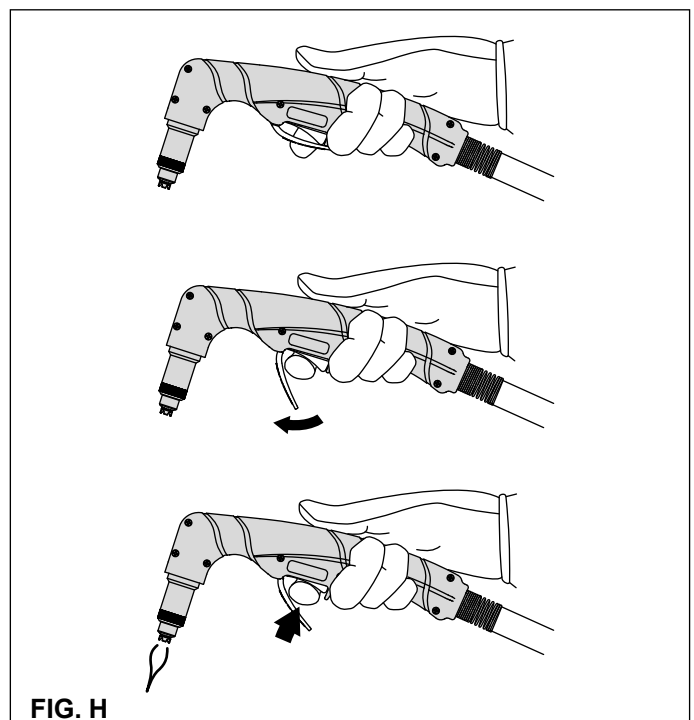
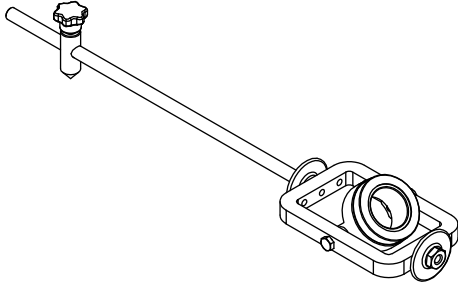

FIG. H

For circular cuts, using the compass kit supplied.



CUTTING FROM THE EDGE OF THE PLATE

With the earth clamp connected to the plate, keep the torch nozzle perpendicular (90-95°) to the edge of the plate.

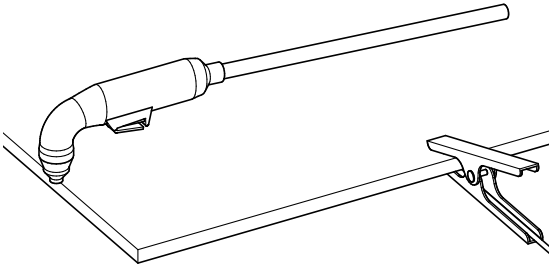

Push the torch button to ignite the arc. Wait at the edge until the arc has cut the plate completely.

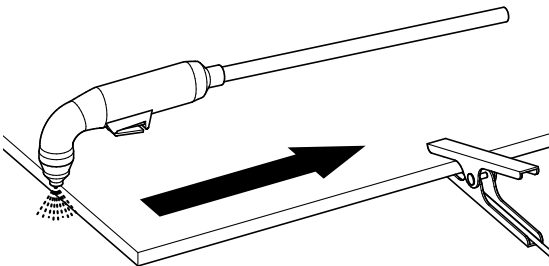

Drag the torch over the plate to do the cut. Maintain a regular, linear pace.

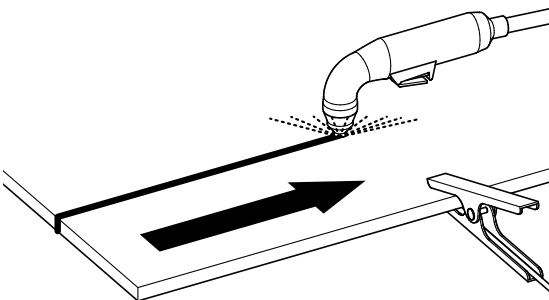

CUTTING FROM WITHIN THE PLATE (PIERCING)

WARNING: Sparks and hot metal can cause injuries to the eyes and the skin.

When the torch is ignited in an inclined position, the sparks and hot metal are projected away from the nozzle. Do not point the torch at yourself or other people nearby.

■ Cutting thin material

With the earth clamp connected to the plate, keep the torch at about 30° to the plate, with the torch shield about 1,5 mm from the plate, before pushing the torch button.

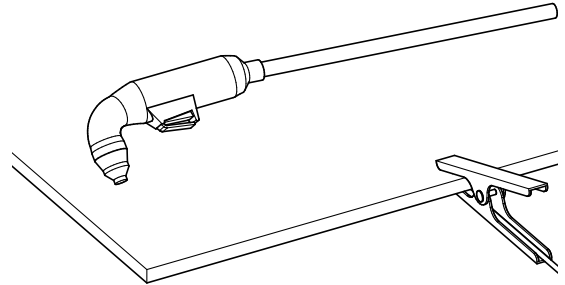

Push the torch button. Slowly rotate the torch to a perpendicular position (90°).

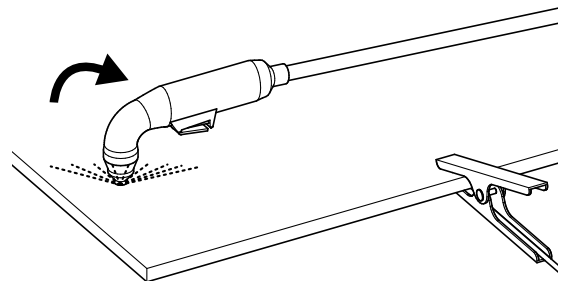

Keep the torch in this position, while continuing to push the button. When the sparks come out from the underside the plate, the arc has pierced the material.

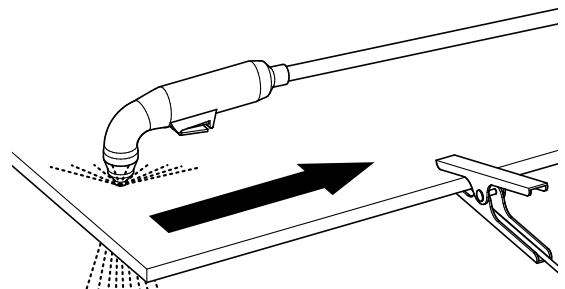

On completion of piercing, drag the nozzle lightly over the plate to make the cut.

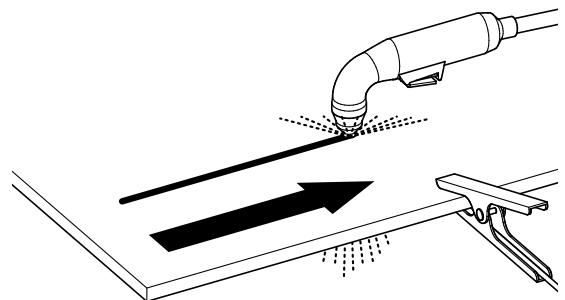

■ Medium / thick material cuts

With the earth clamp connected to the plate, keep the torch raised above the plate.

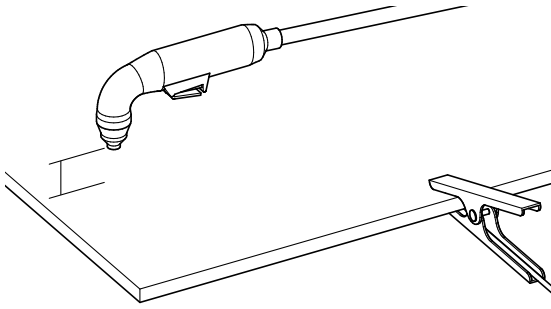

Push the torch button and move slowly towards the plate.

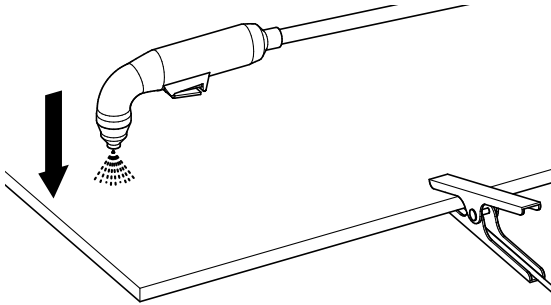

When the sparks come out from the underside the plate, the arc has pierced the material. Once the material has been pierced, the torch's shield can be rested on the material to be cut.

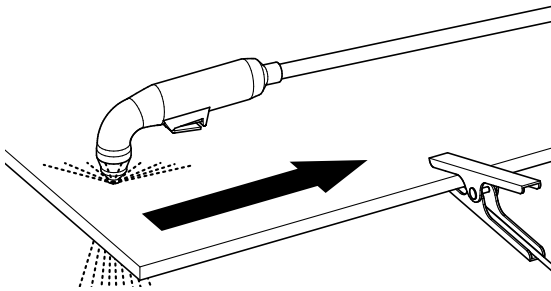

Drag the nozzle lightly over the plate to make the cut.

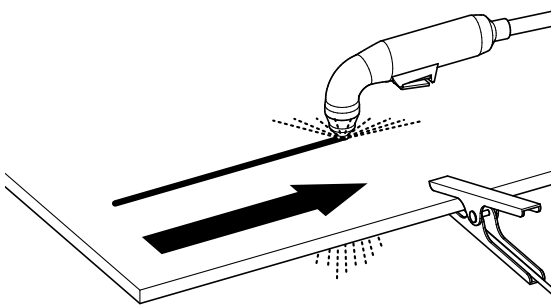

GOUGING THE PLATE

WARNING: The plant must be fed with a constant air flow, with the following characteristics: pressure 3,0-4,5 bar (44-65 psi).

WARNING: Sparks and hot metal can cause injuries to the eyes and the skin.

When the torch is ignited in an inclined position, the sparks and hot metal are projected away from the nozzle. Do not point the torch at yourself or other people nearby.

With the earth clamp connected to the plate, keep the torch at about 45° to the workpiece, with the torch shield about 1,5 mm from the plate, before pushing the torch button.

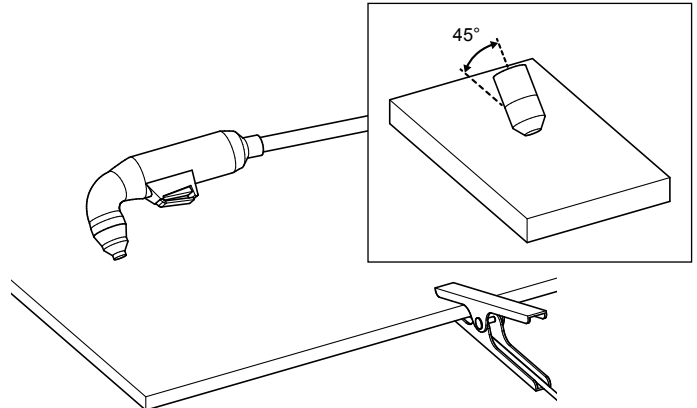

Keep the torch at 45° to the plate, leaving a small gap between the torch shield and the plate. Push the trigger to ignite the pilot arc. Transfer the arc to the plate.

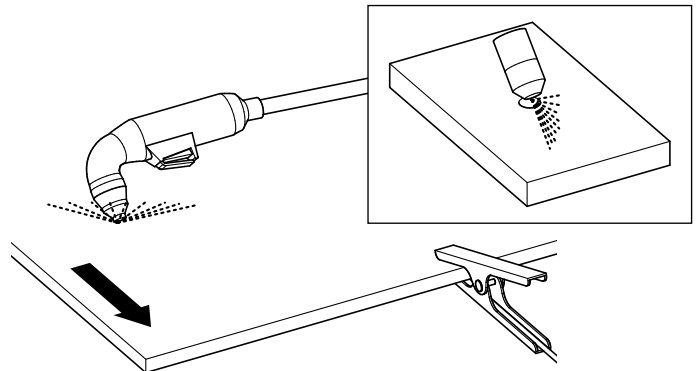

Maintain the 45° angle to the plate, while executing gouging. Push the plasma arc in the direction of the gouge you wish to form. Maintain a small gap between the torch shield and the molten metal, to avoid reducing the lifespan of consumables or damaging the torch. If the torch angle is changed, the dimensions of the gouge also change.

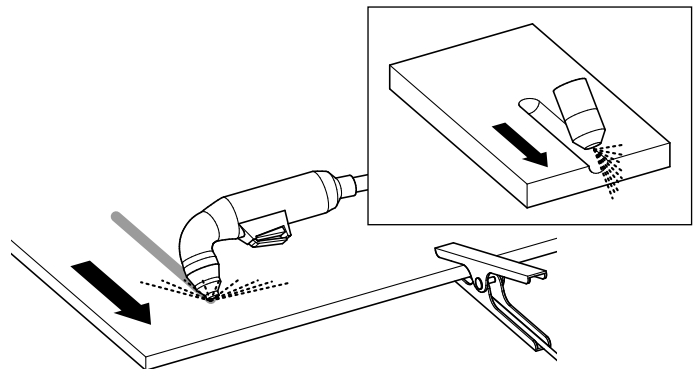

The gouge profile can be varied by varying the speed at which the torch passes over the plate, changing the distance between the torch and the plate, changing the angle between the torch and the plate, and by changing the output current on the generator.

The following actions have the relevant effect on the gouge profile:

		Gouge profile width	Gouge profile depth
Torch speed	+	-	-
	-	+	+
Distance between torch and plate	+	+	-
	-	-	+
Torch angle	+	-	+
	-	+	-
Generator current	+	+	+
	-	-	-

⊕ = increase (or more vertical angle)

⊖ = decrease (or less vertical angle)

COMMON ERRORS FOR MANUAL CUTTING

Problem	Cause
The torch does not cut the plate completely.	The cutting speed is too high.
	The consumables are worn.
	The metal to be cut is too thick for the voltage selected.
	Gouging consumables are fitted, instead of cutting consumables.
	The earth clamp is not connected to the plate correctly.
The quality of the cut is poor.	The gas pressure or flow rate is too low.
	The metal to be cut is too thick for the voltage.
	The wrong consumables are being used (e.g. gouging consumables are used instead of cutting consumables).
The arc splutters and the lifespan of consumables is shorter than envisaged.	The torch is being moved too fast or too slow.
	Moisture in the gas supply.
	Incorrect gas pressure.
	Consumables fitted incorrectly.









Configuring the torch for automatic cutting

INTRODUCTION

These machines are supplied with the following standard torches for automatic cutting:

Other lengths are available by request.

The torches are air cooled, and do not require special cooling. The main nominal characteristics of the torches supplied, are as follows:

	PoWer CUT 155
	PoWer CUT 155 = 6/12 m (standard) (other lengths by request)
	160 A @ 60% (10 min. 40°C)
	DC
	Cutting: 5,0-6,0 bar / 72-87 psi Gas flow @ 160 A: 420 l/min - 890 cfh
	AIR - Clean, dry, oil-free for ISO 8573-1 Class 1.2.2 N₂ - 99.95%
	M
	Without HF
	IEC 60974-7

WORKING LIFESPAN OF CONSUMABLES

The following factors affect the frequency with which consumables need to be replaced:

- Thickness of the metal cut.
- Average cut length.
- Air quality (presence of oil, moisture, or other pollutants).
- Execution of piercing of the metal or cutting from the edge.
- Correct piercing depth.
- Cutting done using mesh or solid material cutting mode. Cutting done in mesh mode give rise to more wear of consumables.

Under normal conditions, the nozzle wears out before the other consumables during cutting operations.

CONSUMABLES FOR AUTOMATIC CUTTING

Figure I shows the consumables used for the plasma torches supplied, complete with the GeKaMac order codes.

FITTING CONSUMABLES ON THE TORCH FOR AUTOMATIC CUTTING

WARNING: Before changing consumables, check that the machine's main switch is in the O position.

To use the torch for automatic cutting, a complete set of consumables must be fitted, as shown in figure L. An outside nozzle holder is available with an Ohmic sensor, which is to be used with shielded consumables.

EQUIPPING THE TORCH FOR AUTOMATIC CUTTING

The torches for automatic cutting can be fitted on a wide range of X-Y-Z benches, motorised equipments, bevellers for tubes, and other equipment. Install the torch according to the manufacturer's instructions.

Fit the PoWer CUT 155 perpendicular to the plate, to achieve a vertical cut. Use a square to align the torch at 90° (Fig. M).

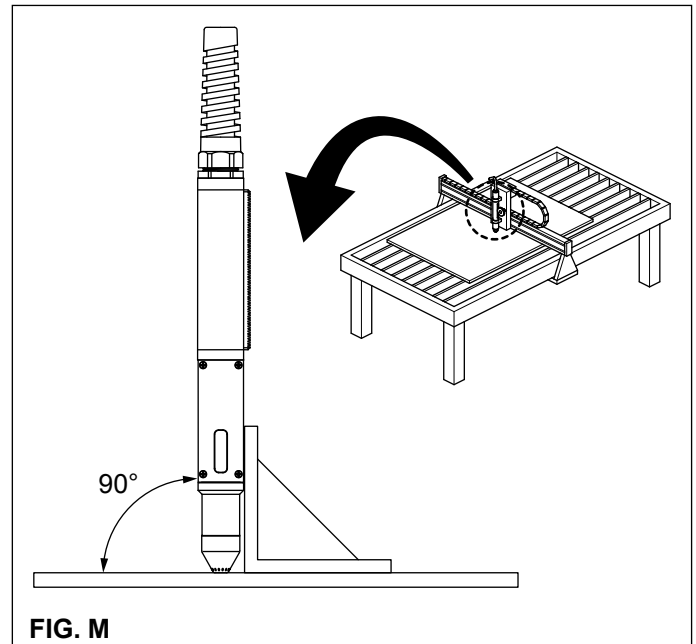
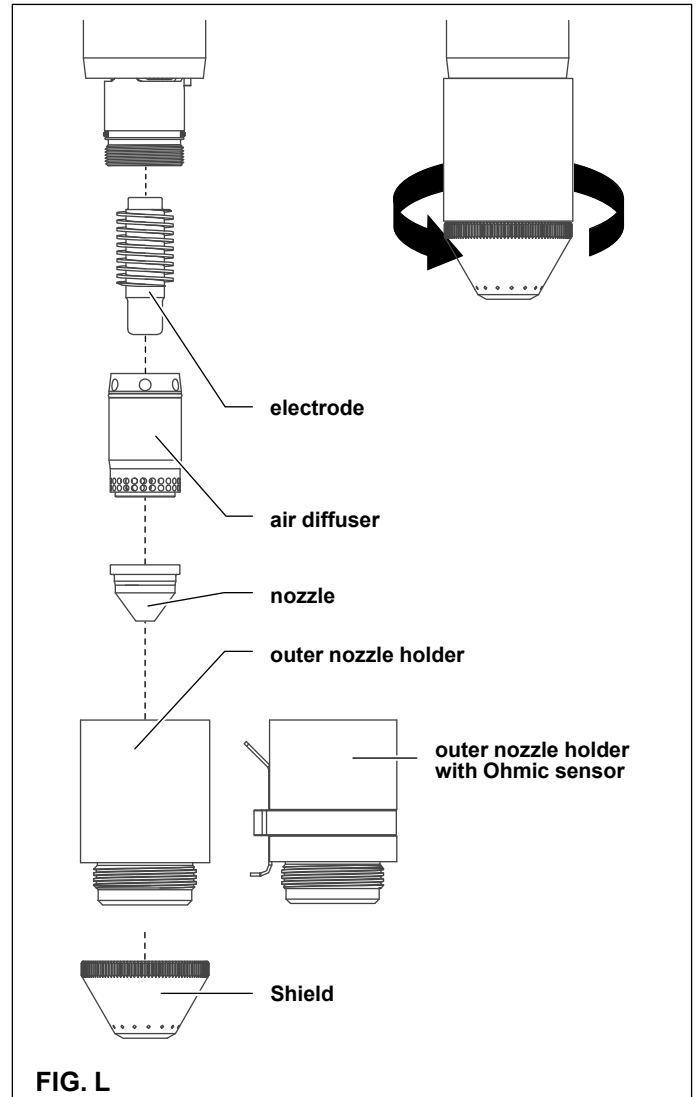

Signal	Type	Notes	Pole n°	Wire colour
Start cut	Input	An isolated contact has to be closed for activation to occur. The characteristics of this contact are: voltage > 20 Vdc; current > 10 mA.	3 4	Green Green
Arc transferred Start machine movement	Output	Closure of isolated photo relay contact. This contact's characteristics are as follows: • Max voltage 60 Vdc • Max current 400 mAdc Alternating current (AC) is not allowed.	12 (+) 14 (-)	White (+) Brown (-)
Earth protection (PE)	Earth		13	Yellow Green
Reduced cutting voltage	Output	Signal proportional to the cutting voltage, not galvanically isolated, according to the following ratios: 1:50 (factory setting); 1:20; 1:21; 1:30; 1:40.	5 (-) 6 (+)	Black (-) Red (+)

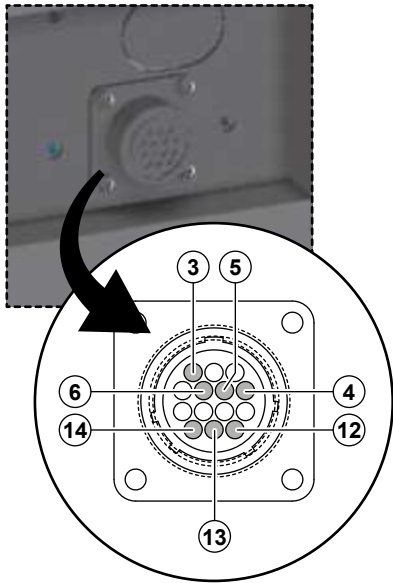

CNC	Female 14 pole connector
Vd	Green wire
Nr	Black wire
Rs	Red wire
Bc	White wire
Mr	Brown wire
GV	Yellow / green wire

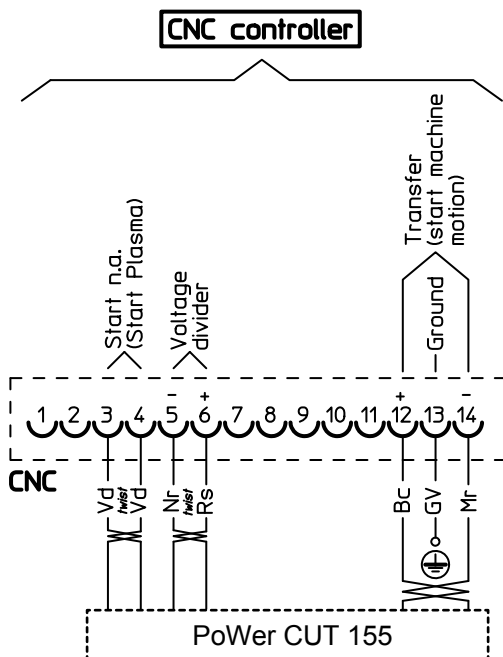

FIG. N

If the cutting bench's guides and transmission system are cleaned, checked and optimised, the torch moves easily. Unsteady movement of the machine can give rise to an undulating, irregular path on the cutting surface.

Make sure that the torch does not touch the plate while cutting. Contact could damage the shield and nozzle, and affect the cut surface.

Having connected to the torch to the X-Y-Z bench, screw it to the centralised connection on the PoWer CUT 155 system generator. The two-pole cable that sticks out about 2 m from the centralised connection for the PoWer CUT 155 plasma torch, is in series with the start cut button.

Depending on the type of X-Y-Z bench and the software used, the two-pole cable can be used as:

- An additional emergency stopping unit for the mechanised cutting machine.
- A short-circuit for the 2 wires of the two-pole cable, if not used as an emergency stopping unit.

INTERFACE WITH A CNC CONTROLLER PLANT

The special PoWer CUT 155 plasma versions, are already complete with an interface for CNC controller equipments, such as X-Y-Z cutting benches, for example. On the back of the PoWer CUT 155 plant there is a 14-pole female connector (CPC TE Connectivity series) for connecting the CNC interface cable.

This socket makes the following signals available:

- Arc voltage reduced to 1:50 (factory setting) (NOT galvanically isolated signal). Inside the PoWer CUT 155 machine there is a dip-switch that can be used to set other reduced arc voltages:

1:20	1:21	1:30	1:40
------	------	------	------

- Arc transfer / start machine movement signal
- Start cut signal.

The machine interface cable must be installed by a technician from an authorised service centre.

To install the machine's interface cable:

- Disconnect the power supply to the machine, by shifting the switch to the O position.
- Connect the machine's interface cable to the 14-pole CNC controller socket located on the back panel of the PoWer CUT 155 plants. The male 14-pole interface connector (CPC TE Connectivity series) is available from our Company, using order code 460180.

FEMALE 14-POLE MACHINE INTERFACE CONNECTOR OUTPUTS

On the back of the PoWer CUT 155 plant there is a 14-pole female connector (CPC TE Connectivity series) for connecting a CNC controller or a height controller.

The signals available on the machine interface connector, are indicated in figure N.

VOLTAGE DIVIDER SETTINGS

The secondary voltage divider is set in the factory at a value of 1:50.

Inside the machine there is a dip-switch (SW1) that can be used to set 4 other secondary voltage values:

1:20	1:21	1:30	1:40
------	------	------	------

To access the dip-switch (SW1) proceed as follows (Fig. O):

- 1) Disconnect the power supply from the system by turning the line switch on the back panel to the O position. Disconnect the machine's power supply cable from the main power supply socket in the wall.
- 2) Remove the plant's metal lid to access the plant's secondary board.
- 3) Set the dip-switch (SW1) to one of the configurations available.
- 4) Reassemble the machine, following the points above in reverse order.

ROBOMAT1 INTERFACE



The PoWer CUT 155 plants, in their special MR version, can easily be integrated with automatic robotics cutting plants, via the ROBOMAT 1 interface, which handles all process signals and regulates the main cutting parameters.

ROBOMAT 1 is a flexible, efficient interface system that satisfies all Analogue / Digital connection requirements.

In addition to the ROBOMAT 1 interface, on the back of the PoWer CUT 155 plant there is a 14-pole female connector (CPC TE Connectivity) for connecting a CNC controller or a height controller.

The signals available on the machine interface connector, are indicated in figure N.

USING THE MANUAL PLASMA TORCH ON PLASMA PoWer CUT 155, VERSION PLANTS

Manual torches can be used on PoWer CUT 155 version plasma plants for automatic plants as well:



ALL OFF	SW1 ON	SW2 ON	SW3 ON	SW4 ON
1:20	1:21	1:30	1:40	1:50

FIG. O

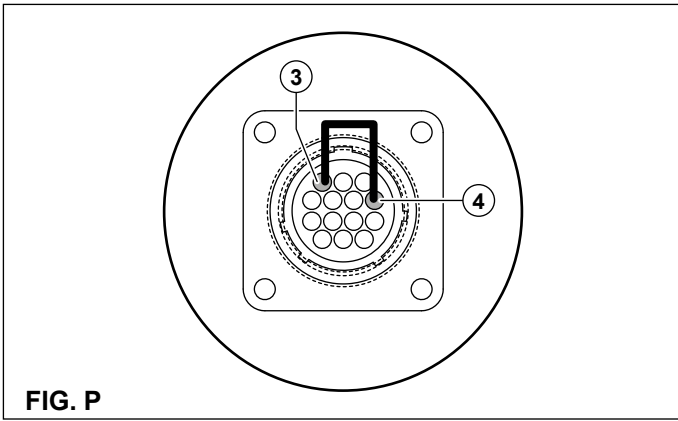

FIG. P

The manual torches can work in PoWer CUT 155 version plants only if terminals 3 and 4 are short-circuited on the 14 pole male connector used to interface with the CNC controller plants (Fig. P).

Code 460180: buying code for the 14 pole male connector used to interface with CNC controller plants.

Using the torch for automatic cutting

WARNING

Torch with immediate ignition

A plasma arc can cause injuries and burns.

The plasma arc ignites immediately, when the torch button is pushed.

The plasma arc passes through gloves and the skin quickly.

Use appropriate equipment to protect your head, eyes, ears, hands, and body.

Keep away from the tip of the torch.

Do not hold the plate and keep your hands away from the cutting path.

Never point the torch at yourself or other people.

SUGGESTIONS FOR USING THE TORCH FOR AUTOMATIC CUTTING

For a better quality cut, the following parameters must be examined:

- Cut angle / cut inclination.
- Burr.
- Straightness of the cut surface. Concave or convex cutting surfaces.

■ Cut angle / cut inclination

This gives the angle of the cut edge, and can be:

Positive angle	Negative angle
<p>This is achieved when a greater quantity of material is removed from the upper part of the cut.</p> <p>Cause Torch too high</p> <p>Solution Lower the torch. If a torch height control is being used, increase the cutting arc voltage.</p>	<p>This is achieved when a greater quantity of material is removed from the lower part of the cut.</p> <p>Cause Torch too low</p> <p>Solution Raise the torch. If a torch height control is being used, reduce the cutting arc voltage.</p>

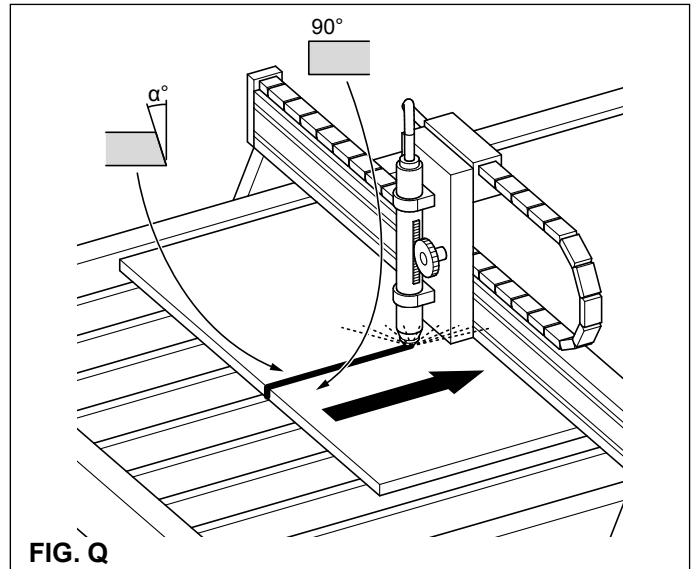

FIG. Q

The angle closest to a right angle will be on the right in relation to the movement of the torch. The left side will always be characterised by an angle other than 90° (Fig. Q).

Often a cutting angle problem is caused by the cutting bench system, and is not due to the plasma machine. Use a square to check the right angle between the torch's position and the plate to be cut.

Set the torch at 90° in the respective torch holder, or reverse the direction of movement, to check whether the cutting problem disappears.

Cutting angle problems can occur if the material to be cut is hardened or magnetised.

■ Burr

Each time a cut is made, some burrs will be formed. The quantity and type of burr can be reduced, by setting the machine correctly in relation to the application.

If the torch is too low or, when using a height control system, the cutting voltage is too low, an excessive burr will be formed on the upper edge of the plate to be cut. To resolve this problem, adjust the torch of the voltage in small steps of about 5V, until the burr is reduced.

In other cases, the excessive burr occurs due to the speed being too low or too high.

Type of burr	Cause	Solution
Heavy deposit on the underside of the cut (can be removed easily).	Speed too low.	Increase the speed.
Slight deposit on the underside of the cut (difficult to remove).	Speed too high.	Reduce the speed.
	Gap between torch and plate too big.	Reduce the gap between the torch and the plate or the cutting voltage, when using height control systems.

CUTTING FROM WITHIN THE PLATE (PIERCING)

As happens for manual cutting, a cut can be made starting from inside the plate (piercing), instead of from the outer edge. It is worth remembering that cutting from inside the plate can shorten the working lifespan of consumables.

When cutting a plate from inside, the following parameters must be considered:

- **Initial piercing height:** about 2-2,5 times the cutting depth, depending on the thickness of the material to be cut.
- **Piercing delay:** period of time for which the ignited torch stays at the piercing height, before it begins moving. A sufficiently long piercing delay must be applied to allow the cutting arc to pierce the material. Subsequently, the torch can be lowered to the normal cutting height. In addition, as wear

on the materials increases, it may be necessary to increase the piercing delay.

For optimum execution of a hole, it is worth considering that the diameter must be more than twice the thickness of the plate.

The chemical properties of the materials, can have an impact on the piercing capacity. For example, a high-strength steel with a high manganese or silica content, may reduce the maximum piercing capacity.

COMMON ERRORS FOR AUTOMATIC CUTTING





Problem	Cause
The pilot arc ignites, but is not transferred.	The earth cable is not making good contact with the cutting bench, or the cutting bench is not making good contact with the plate.
	The torch / plate gap is too big.
The plate has not been penetrated completely and excessive sparks are produced on the upper side of the plate.	Rust or paint on the surface of the plate.
	The consumables are worn and must be replaced.
	The earth cable is not making good contact with the cutting bench, or the cutting bench is not making good contact with the plate.
	The cutting voltage is too low.
	The cutting speed is too high.
Burrs formed at the bottom of the cut.	The cutting thickness is too great.
	The air settings are incorrect.
	The consumables are worn and must be replaced.
	The cutting speed is incorrect.
The cutting angle is not perpendicular.	The voltage is too low.
	The torch is not perpendicular to the plate.
	The air settings are incorrect.
	The consumables are worn and must be replaced.
	The direction of movement of the torch is incorrect. The high quality cut is always to the right in relation to the forward movement of the torch.
	The gap between the torch and plate is incorrect.
The lifespan of consumables is short.	The cutting speed is incorrect.
	The air settings are incorrect.
	The arc current, arc voltage, cutting speed, and other variables are not configured correctly.
	Ignite the arc in the air (start of end the cut outside the plate's surface). It is possible to start from the edge, provided the arc is in contact with the plate when ignited.
	Beginning of piercing with the torch at the wrong height.
	The piercing time is incorrect.
	The air quality is poor (oil or water in the air). Use the additional filtration system, GeKaMac code 427529 (Fig. D) with a filtration grade of 0,01 µinch - 0,25 µm available via GeKaMac distributors (the order code for replacement filters is 427530).

Automatic CNC cutting tables

The following pages contain the cutting tables for each series of consumables for automatic cutting of the following materials:

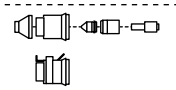
- Mild steel.
- Stainless steel (CrNi).
- Aluminium.

Each table contains the following information:

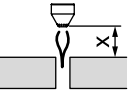
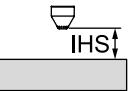
	Cutting current setting.
Fe	Carbon steel Fe 430 B - S275JR
CrNi	Stainless steel Aisi 304 / X5 CrNi 18-10
Al	Aluminium
	Torch configuration, complete with codes for consumables to be fitted on the plasma torch.
	Air pressure setting.
	Indication of the air flow rate (cold air condition).
	Cutting gas indication.
mm	Metric system.
in	Imperial system.
	Thickness of the material to be cut.
	Cutting height. • Shielded consumables: gap between the shield and the piece to be cut. • Non-shielded consumables: gap between the nozzle and the piece to be cut.
	Initial piercing height. This is the initial gap between the shield (shielded consumables) or the nozzle (non-shielded consumables) and the piece to be cut, when the arc is ignited, before going down to the cutting height. The percentage value indicates the increment in cutting height, to obtain the initial piercing height.

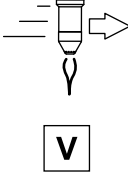
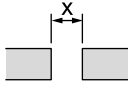
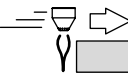
	Piercing delay. The period of time for which the torch, with the arc ignited, remains at the initial piercing height, before beginning the cutting movement at the final cutting height.
	Cutting speed and arc voltage settings (THC systems with torch height control), which indicate the starting point for finding the best parameters for achieving the desired result.
PRODUCTION	Production quality. To obtain a good cutting angle (0-10°), and acceptable burrs and surface finish. These parameters make it possible to produce a larger number of cut pieces, but not necessarily with the best quality cut possible.
QUALITY	Maximum quality. To obtain the best cutting angle (*) minimum burrs, and the best cutting surface finish. (*) 0-6° using standard consumables, and 0-4° using CLEAN-CUT consumables.
	"Kerf" cutting width. The values indicated in the cutting tables are indicative and are obtained using the maximum quality settings.
	Starting from the edge.

NOTE: The arc voltage increases with wearing of the consumables, and so the voltage settings must be increased in order to maintain the correct gap between torch and plating.

NOTE: The data in the table was obtained during laboratory tests using new consumables and taking the ISO 9013 international standard as a reference. The precision of plasma cuts depends basically on the interaction between the plasma plant, the guide system, and the height control. The cutting speed also affects the inclination of the cutting surface.

PoWer CUT 155





I₂

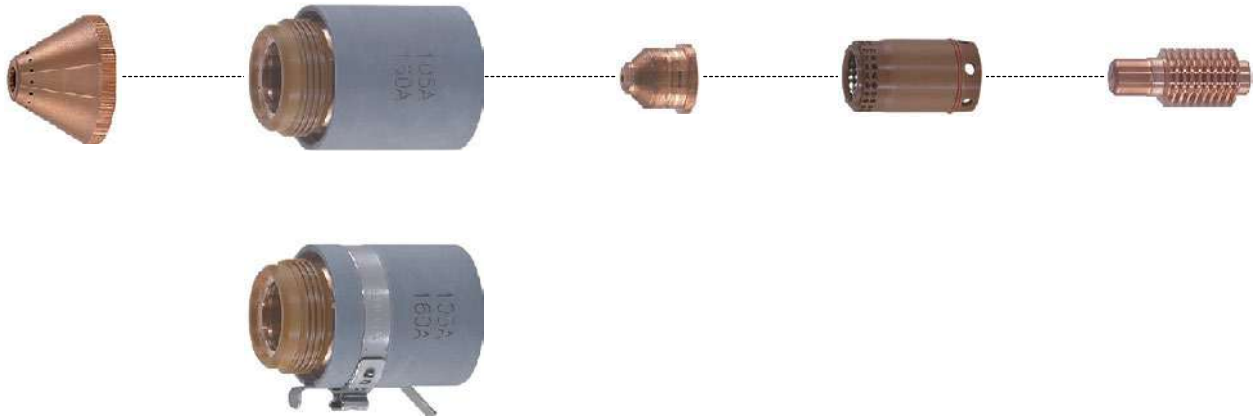



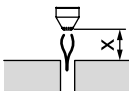
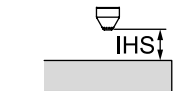
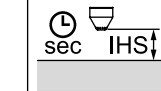
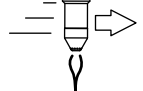
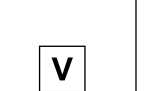
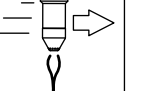

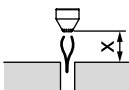

150 A

Fe

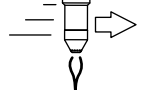

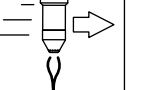
P 5,5 bar 80 psi	 375 l/min 795 cfh	AIR AIR - Clean, dry, oil-free for ISO 8573-1 Class 1.2.2
----------------------------	--	--

mm					PRODUCTION		QUALITY		
									
mm	mm	mm	%	sec	mm/min	V	mm/min	V	mm
6	5	10	200	0,2	6560	158	5480	161	2,3
8	5	10	200	0,3	5030	160	4180	163	2,4
10	5	10	200	0,4	3665	161	3025	164	2,6
12	5	10	200	0,5	2765	163	2255	166	2,7
16	5	12,5	250	0,6	1830	167	1390	167	2,9
20	5	12,5	250	1,7	1255	169	1080	168	3,2
25	5	12,5	250	3,1	860	170	675	172	3,4
30	5				565	172	480	174	3,7
32	5				550	175	460	177	4,0
35	5				475	178	375	180	4,3
40	5				345	181	265	183	4,5
45	5				265	185	200	186	4,9
50	5				160	189	145	191	5,5

in					PRODUCTION		QUALITY		
									
inches	inches	inches	%	sec	ipm	V	ipm	V	inches
1/4"	0.195"	0.39"	200	0.2	244	158	204	161	0.095"
3/8"	0.195"	0.39"	200	0.4	151	161	125	164	0.10"
1/2"	0.195"	0.39"	200	0.5	103	164	84	166	0.11"
5/8"	0.195"	0.49"	250	0.6	73	167	55	167	0.12"
3/4"	0.195"	0.49"	250	1.6	54	168	46	168	0.13"
7/8"	0.195"	0.49"	250	2	52	170	45	169	0.14"
1"	0.195"	0.49"	250	3.1	33	172	26	172	0.14"
1-1/4"	0.195"				22	175	18	177	0.16"
1-1/2"	0.195"				14	179	11	181	0.17"
1-3/4"	0.195"				11	184	8	185	0.19"
2"	0.195"				6	190	5	192	0.22"

PoWer CUT 155





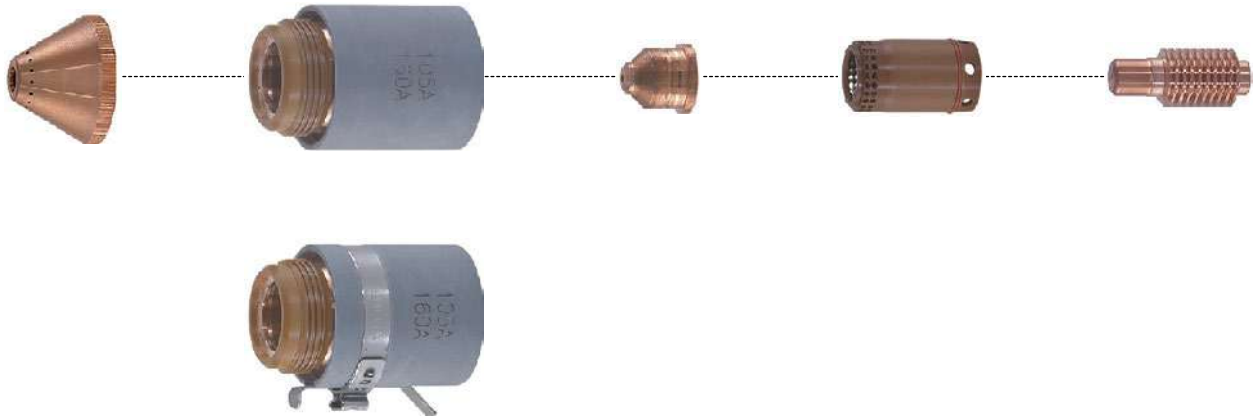

I₂



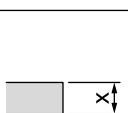
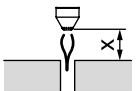
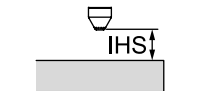

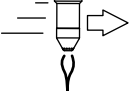

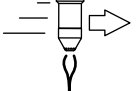
150 A

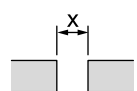
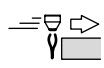
CrNi

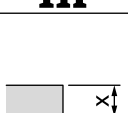
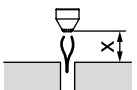

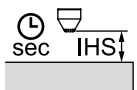
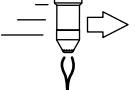
P 5,5 bar 80 psi	 375 l/min 795 cfh	AIR AIR - Clean, dry, oil-free for ISO 8573-1 Class 1.2.2
----------------------------	--	--

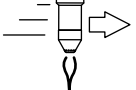
mm					PRODUCTION		QUALITY		
									
mm	mm	mm	%	sec	mm/min	V	mm/min	V	mm
6	5	10	200	0,5	8460	160	6505	159	2,3
8	5	10	200	0,5	6105	161	4470	160	2,5
10	5	10	200	0,55	4070	162	2795	162	2,6
12	5	10	200	0,55	2985	164	2390	166	2,8
16	5	12,5	250	0,7	1610	165	1255	168	3
20	5	12,5	250	1,2	1135	166	1035	170	3,2
25	5				840	169	695	175	3,4
30	5				675	170	565	176	3,6
32	5				660	172	520	180	3,8
35	5				495	176	355	183	4,0
40	5				235	182	200	188	4,2
45	5				185	186	165	191	4,7
50	5				140	190	125	195	5,4

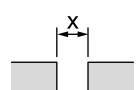
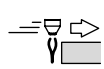
in					PRODUCTION		QUALITY		
									
inches	inches	inches	%	sec	ipm	V	ipm	V	inches
1/4"	0.195"	0.39"	200	0,5	315	161	242	160	0,096"
3/8"	0.195"	0.39"	200	0,55	168	162	116	161	0,098"
1/2"	0.195"	0.39"	200	0,55	111	164	89	165	0,11"
5/8"	0.195"	0.49"	250	0,7	64	165	50	166	0,115"
3/4"	0.195"	0.49"	250	1,1	47	166	43	167	0,12"
7/8"	0.195"	0.49"	250	1,4	40	167	37	172	0,13"
1"	0.195"				33	169	27	175	0,14"
1-1/4"	0.195"				26	172	21	180	0,15"
1-1/2"	0.195"				10	178	8	186	0,16"
1-3/4"	0.195"				8	185	7	190	0,18"
2"	0.195"				6	190	5	195	0,22"

PoWer CUT 155





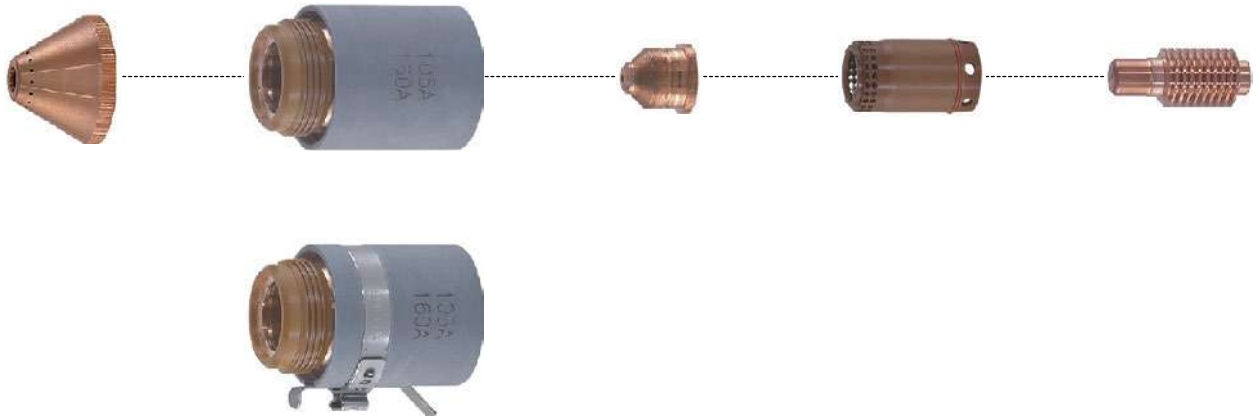

l₂



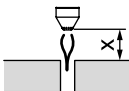
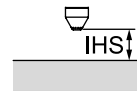

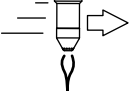

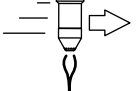
150 A

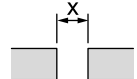
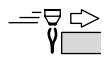
Al

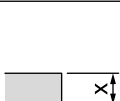
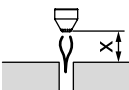

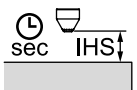
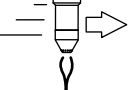
P 5,5 bar 80 psi	 375 l/min 795 cfh	AIR AIR - Clean, dry, oil-free for ISO 8573-1 Class 1.2.2
----------------------------	--	--

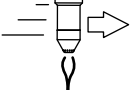
mm					PRODUCTION		QUALITY		
									
mm	mm	mm	%	sec	mm/min	V	mm/min	V	mm
6	5	10	200	0,2	9420	159	8430	162	2,4
8	5	10	200	0,3	6710	160	5610	164	2,6
10	5	10	200	0,4	4425	162	3280	166	2,8
12	5	10	200	0,5	3380	165	2355	168	3,0
16	5	12,5	250	0,6	2300	166	1695	172	3,3
20	5	12,5	250	1,7	1650	170	1390	173	3,4
25	5	12,5	250	3,2	1155	171	935	177	3,5
30	5				895	172	840	178	3,7
32	5				860	177	825	185	3,9
35	5				640	179	580	186	4,2
40	5				330	182	300	188	4,5
45	5				250	186	220	191	4,9
50	5				160	190	130	195	5,5

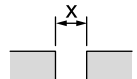
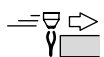
in					PRODUCTION		QUALITY		
									
inches	inches	inches	%	sec	ipm	V	ipm	V	inches
1/4"	0.195"	0.39"	200	0,2	350	160	314	163	0,10"
3/8"	0.195"	0.39"	200	0,4	183	161	136	165	0,105"
1/2"	0.195"	0.39"	200	0,5	126	164	88	169	0,125"
5/8"	0.195"	0.49"	250	0,6	91	166	67	172	0,128"
3/4"	0.195"	0.49"	250	1,6	71	168	60	173	0,130"
7/8"	0.195"	0.49"	250	2,1	68	170	57	175	0,14"
1"	0.195"	0.49"	250	3,2	45	171	36	178	0,145"
1-1/4"	0.195"				34	176	33	185	0,15"
1-1/2"	0.195"				14	180	12	186	0,17"
1-3/4"	0.195"				10	185	9	190	0,19"
2"	0.195"				6	190	5	195	0,22"

PoWer CUT 155





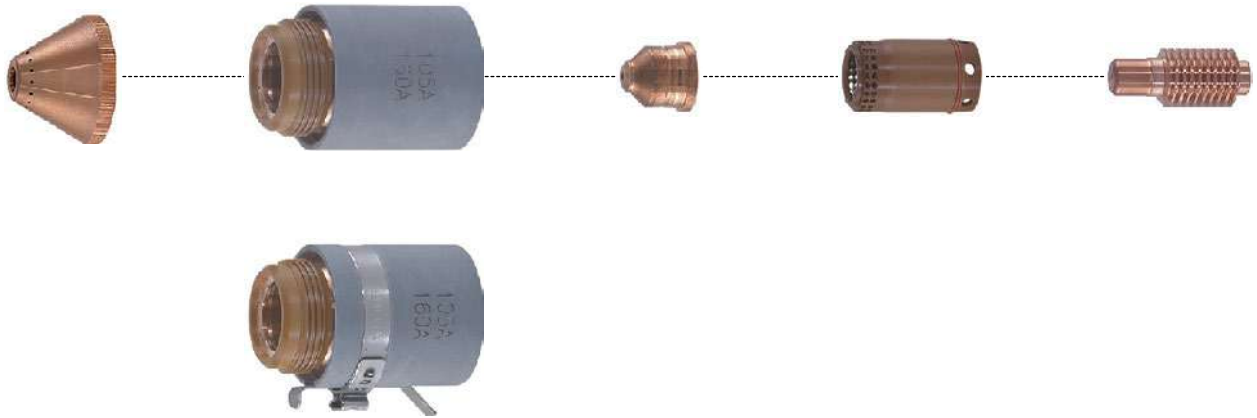

l₂



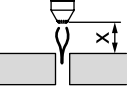
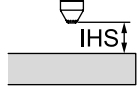
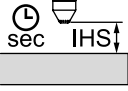
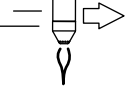

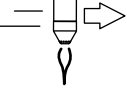

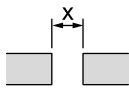

125 A

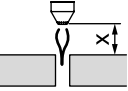
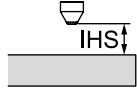
Fe

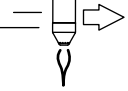

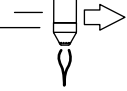
P 5,5 bar 80 psi	 365 l/min 775 cfh	AIR AIR - Clean, dry, oil-free for ISO 8573-1 Class 1.2.2
----------------------------	--	--

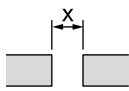
mm					PRODUCTION		QUALITY		
									
mm	mm	mm	%	sec	mm/min	V	mm/min	V	mm
6	4	8	200	0,3	5360	153	4480	156	2,1
8	4	8	200	0,35	4110	155	3420	156	2,2
10	4	8	200	0,45	2990	156	2470	156	2,3
12	4	8	200	0,55	2250	155	1840	155	2,4
16	4	10	250	0,65	1490	162	1130	160	2,6
20	4	10	250	1,8	1020	162	880	163	2,8
25	4	10	250	3,2	700	165	590	167	3
30	4				490	165	410	167	3,5
32	4				450	170	380	172	3,9
35	4				380	173	310	175	4
40	4				270	176	220	178	4,2

in					PRODUCTION		QUALITY		
									
inches	inches	inches	%	sec	ipm	V	ipm	V	inches
1/4"	0.16"	0.32"	200	0.3	202	153	169	156	0.09"
3/8"	0.16"	0.32"	200	0.4	124	156	102	156	0.095"
1/2"	0.16"	0.32"	200	0.55	83	156	67	156	0.096"
5/8"	0.16"	0.4"	250	0.6	59	162	45	160	0.105"
3/4"	0.16"	0.4"	250	1.7	43	161	37	162	0.11"
7/8"	0.16"	0.4"	250	2	33	164	27	166	0.111"
1"	0.16"	0.4"	250	3.25	27	165	20	167	0.125"
1-1/4"	0.16"				18	170	14	172	0.152"
1-1/2"	0.16"				12	175	9	177	0.16"

PoWer CUT 155







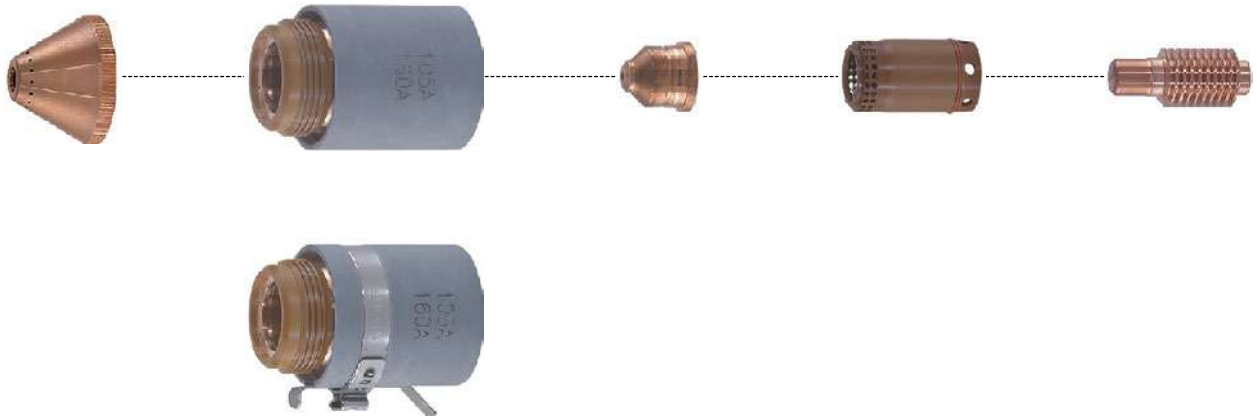

l₂

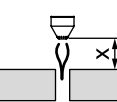

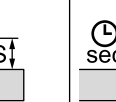
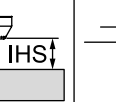
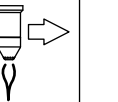

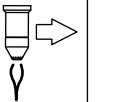

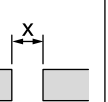
125 A

CrNi

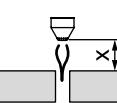

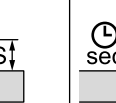
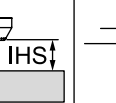
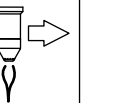
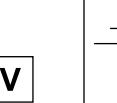
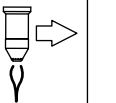
P 5,5 bar 80 psi	 365 l/min 775 cfh	AIR AIR - Clean, dry, oil-free for ISO 8573-1 Class 1.2.2
----------------------------	--	--

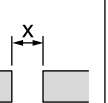
mm					PRODUCTION		QUALITY		
									
mm	mm	mm	%	sec	mm/min	V	mm/min	V	mm
6	4	8	200	0,55	6920	155	5310	154	2
8	4	8	200	0,55	4990	155	3650	155	2,2
10	4	8	200	0,6	3330	155	2280	157	2,3
12	4	8	200	0,6	2430	155	1950	161	2,4
16	4	10	250	0,75	1310	160	1020	163	2,5
20	4	10	250	1,3	920	161	840	165	2,7
25	4				680	164	480	170	2,9
30	4				540	164	450	171	3
32	4				510	167	380	175	3,1
35	4				400	171	280	178	3,3
40	4				180	177	160	183	3,5

in					PRODUCTION		QUALITY		
									
inches	inches	inches	%	sec	ipm	V	ipm	V	inches
1/4"	0.16"	0.32"	200	0.55	259	155	198	154	0.079"
3/8"	0.16"	0.32"	200	0.55	138	155	93	156	0.095"
1/2"	0.16"	0.32"	200	0.6	88	156	70	161	0.105"
5/8"	0.16"	0.4"	250	0.7	52	160	40	163	0.105"
3/4"	0.16"	0.4"	250	1.2	38	161	36	165	0.105"
7/8"	0.16"				31	162	27	166	0.114"
1"	0.16"				26	164	18	171	0.125"
1-1/4"	0.16"				21	167	14	175	0.118"
1-1/2"	0.16"				10	175	8	181	0.139"

PoWer CUT 155





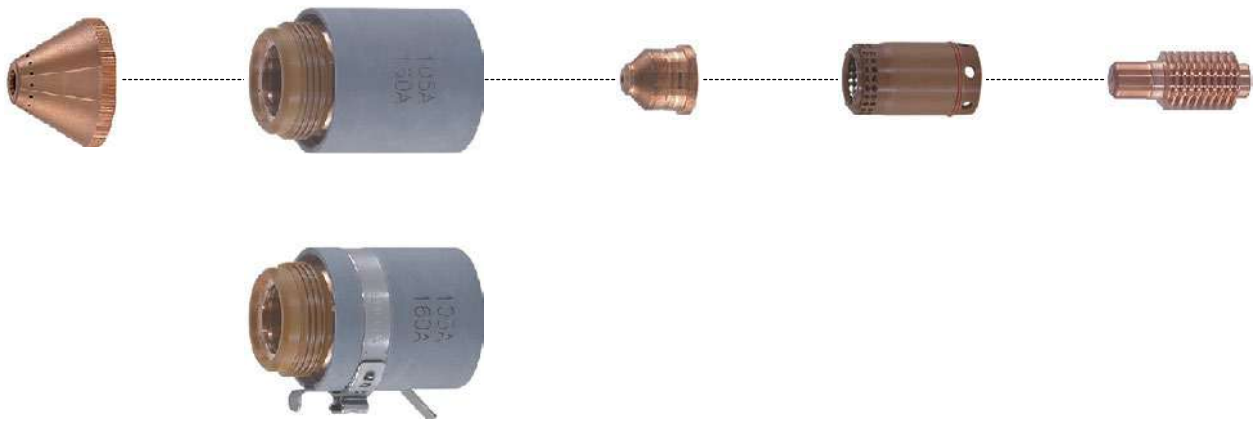

l₂



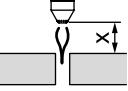
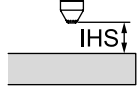
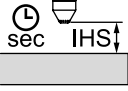
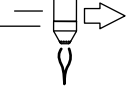

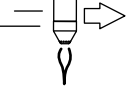

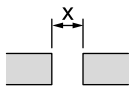

125 A

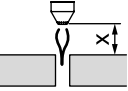
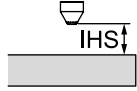
Al

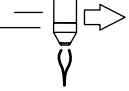

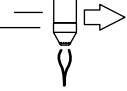
P 5,5 bar 80 psi	 365 l/min 775 cfh	AIR AIR - Clean, dry, oil-free for ISO 8573-1 Class 1.2.2
----------------------------	--	--

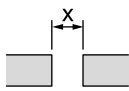
mm					PRODUCTION		QUALITY		
									
mm	mm	mm	%	sec	mm/min	V	mm/min	V	mm
6	4	8	200	0,25	7700	154	6890	157	2,2
8	4	8	200	0,3	5490	155	4590	159	2,4
10	4	8	200	0,45	3610	157	2680	161	2,5
12	4	8	200	0,5	2760	160	1920	163	2,6
16	4	10	250	0,7	1880	161	1380	167	2,7
20	4	10	250	1,9	1350	165	1130	168	2,8
25	4	10	250	3,4	940	165	760	172	2,9
30	4				700	165	650	173	3
32	4				670	172	600	180	3,1
35	4				520	174	450	181	3,4
40	4				270	177	240	183	3,6

in					PRODUCTION		QUALITY		
									
inches	inches	inches	%	sec	ipm	V	ipm	V	inches
1/4"	0.16"	0.32"	200	0.25	288	154	255	157	0.092"
3/8"	0.16"	0.32"	200	0.4	149	156	111	161	0.105"
1/2"	0.16"	0.32"	200	0.5	102	160	72	164	0.106"
5/8"	0.16"	0.4"	250	0.65	74	161	54	167	0.112"
3/4"	0.16"	0.4"	250	1.8	55	165	46	168	0.121"
7/8"	0.16"	0.4"	250	3	46	165	39	169	0.103"
1"	0.16"	0.4"	250	3.45	36	165	28	173	0.114"
1-1/4"	0.16"				27	172	15	180	0.118"
1-1/2"	0.16"				14	176	10	182	0.142"

PoWer CUT 155





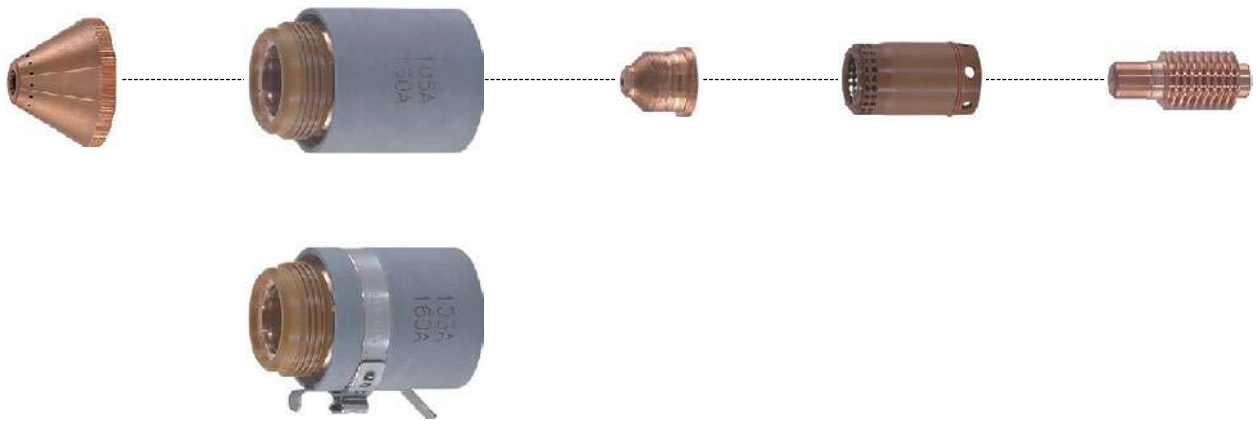

I₂



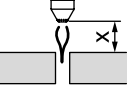
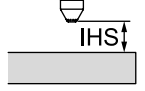
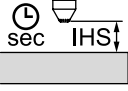
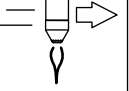

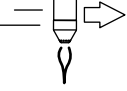

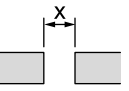

105 A

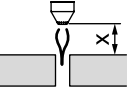
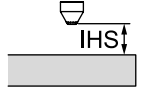
Fe

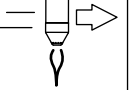

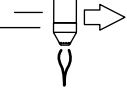
P 5,5 bar 80 psi	 360 l/min 760 cfh	AIR AIR - Clean, dry, oil-free for ISO 8573-1 Class 1.2.2
----------------------------	--	--

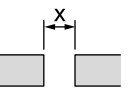
mm					PRODUCTION		QUALITY		
									
mm	mm	mm	%	sec	mm/min	V	mm/min	V	mm
6	4	8	200	0,55	4420	144	3690	156	2
8	4	8	200	0,6	3390	148	2890	156	2,1
10	4	8	200	0,65	2450	151	2160	157	2,2
12	4	8	200	0,7	1780	154	1620	161	2,3
16	4	10	250	0,95	1100	153	940	163	2,4
20	4	10	250	1,2	760	155	700	166	2,6
25	4				520	160	480	172	2,8
30	4				390	166	370	174	3,1
32	4				360	168	330	175	3,2

in					PRODUCTION		QUALITY		
									
inches	inches	inches	%	sec	ipm	V	ipm	V	inches
1/4"	0.16"	0.32"	200	0.55	167	145	140	156	0.081"
3/8"	0.16"	0.32"	200	0.6	102	150	90	156	0.089"
1/2"	0.16"	0.32"	200	0.7	65	154	59	161	0.092"
5/8"	0.16"	0.4"	250	0.9	44	153	37	163	0.095"
3/4"	0.16"	0.4"	250	1.1	31	154	29	166	0.1"
7/8"	0.16"	0.4"	250	0.95	27	156	23	167	0.105"
1"	0.16"				19	161	18	173	0.109"
1-1/4"	0.16"				14	168	13	175	0.127"

PoWer CUT 155





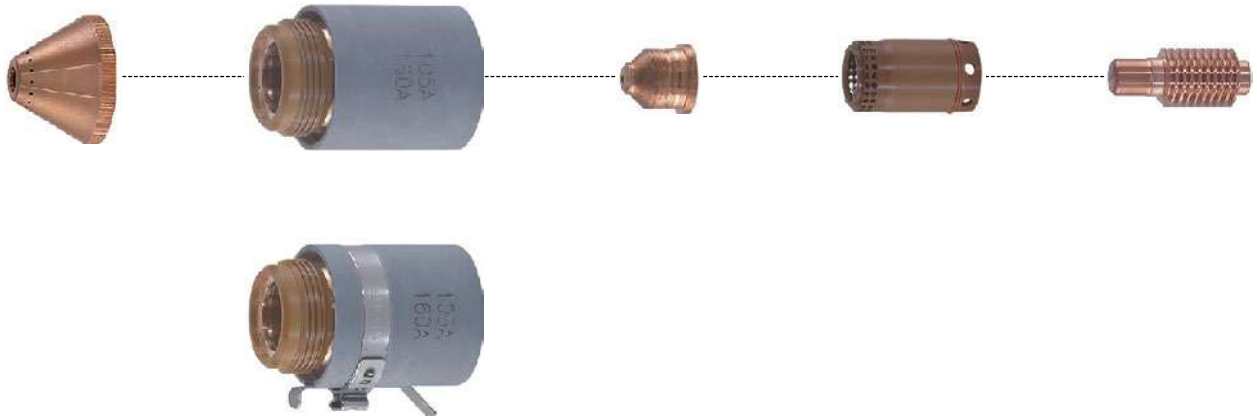

I₂



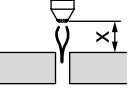
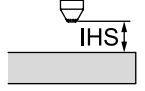
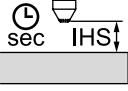
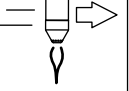

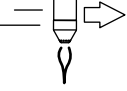

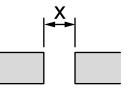

105 A

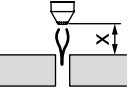
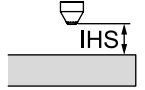
CrNi

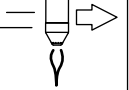

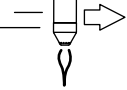
P 5,5 bar 80 psi	 360 l/min 760 cfh	AIR AIR - Clean, dry, oil-free for ISO 8573-1 Class 1.2.2
----------------------------	--	--

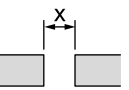
mm					PRODUCTION		QUALITY		
									
mm	mm	mm	%	sec	mm/min	V	mm/min	V	mm
6	4	8	200	0,55	5200	142	4780	156	1,7
8	4	8	200	0,55	3540	146	3280	157	1,9
10	4	8	200	0,55	2170	149	2000	158	2,1
12	4	8	200	0,55	1780	152	1310	160	2,2
16	4	10	250	0,95	850	154	940	164	2,3
20	4	10	250	2,3	650	156	590	167	2,4
25	4				460	160	390	172	2,8
30	4				400	165	290	174	2,9
32	4				370	167	260	175	3

in					PRODUCTION		QUALITY		
									
inches	inches	inches	%	sec	ipm	V	ipm	V	inches
1/4"	0.16"	0.32"	200	0.55	201	143	178	156	0.068"
3/8"	0.16"	0.32"	200	0.5	90	148	84	158	0.086"
1/2"	0.16"	0.32"	200	0.55	63	152	49	161	0.092"
5/8"	0.16"	0.4"	250	0.9	34	154	37	164	0.095"
3/4"	0.16"	0.4"	250	2.15	27	155	25	166	0.094"
7/8"	0.16"				23	157	19	170	0.113"
1"	0.16"				18	161	15	172	0.118"
1-1/4"	0.16"				15	167	10	175	0.118"

PoWer CUT 155





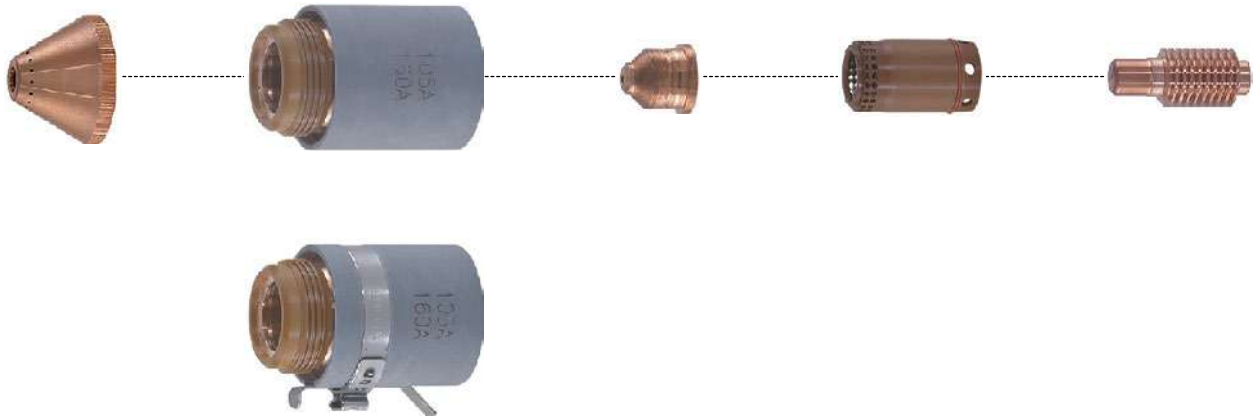

l₂



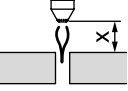
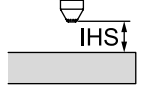
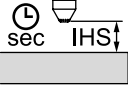
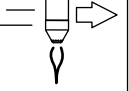

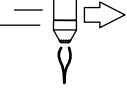

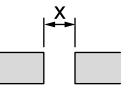
105 A

Al

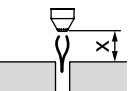
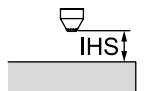
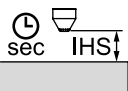
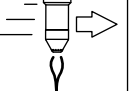

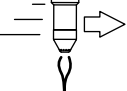
P 5,5 bar 80 psi	 360 l/min 760 cfh	AIR AIR - Clean, dry, oil-free for ISO 8573-1 Class 1.2.2
----------------------------	--	--

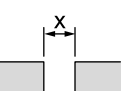
mm					PRODUCTION		QUALITY		
									
mm	mm	mm	%	sec	mm/min	V	mm/min	V	mm
6	4	8	200	0,55	5750	152	5700	156	1,8
8	4	8	200	0,6	4220	152	3890	160	1,9
10	4	8	200	0,75	2920	153	2390	162	2
12	4	8	200	0,8	2330	157	1810	165	2,1
16	4	10	250	0,95	1390	155	1210	167	2,2
20	4	10	250	1,2	910	159	870	170	2,3
25	4				720	165	590	174	2,5
30	4				520	172	410	178	2,5
32	4				440	174	350	180	2,6

in					PRODUCTION		QUALITY		
									
inches	inches	inches	%	sec	ipm	V	ipm	V	inches
1/4"	0.16"	0.32"	200	0.55	216	152	212	157	0.076"
3/8"	0.16"	0.32"	200	0.7	120	152	99	162	0.087"
1/2"	0.16"	0.32"	200	0.8	85	157	67	165	0.086"
5/8"	0.16"	0.4"	250	0.9	55	155	48	167	0.084"
3/4"	0.16"	0.4"	250	1.1	37	158	36	169	0.084"
7/8"	0.16"	0.4"	250	1.3	33	162	30	171	0.088"
1"	0.16"				27	165	22	174	0.103"
1-1/4"	0.16"				18	174	14	180	0.101"

PoWer CUT 155





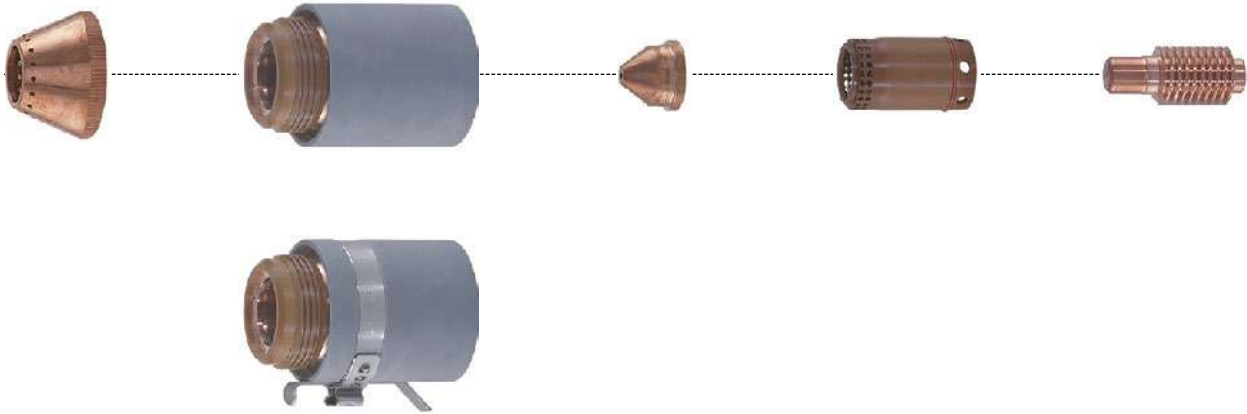

l₂



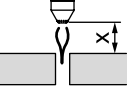
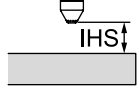
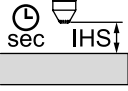
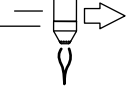

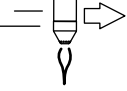

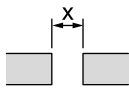
85 A

Fe

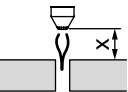
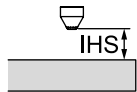
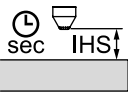
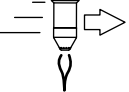

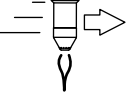
P 5,5 bar 80 psi	 355 l/min 750 cfh	AIR AIR - Clean, dry, oil-free for ISO 8573-1 Class 1.2.2
----------------------------	--	--

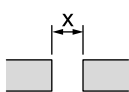
mm					PRODUCTION		QUALITY		
									
mm	mm	mm	%	sec	mm/min	V	mm/min	V	mm
3	2	4	200	0,2	8740	121	6460	123	1,7
4	2	4	200	0,3	6930	123	5360	123	1,7
6	2	4	200	0,6	4180	126	3420	124	1,8
8	2	4	200	0,6	2940	128	2370	126	1,9
10	2	4	200	0,6	1960	129	1590	128	2,0
12	2	5	250	0,8	1520	131	1210	131	2,2
16	2	5	250	1,2	880	134	820	135	2,4
20	2	6	300	1,7	640	137	540	138	2,6
25	2				420	142	330	143	3,2
30	2				280	145	190	147	3,7

in					PRODUCTION		QUALITY		
									
inches	inches	inches	%	sec	ipm	V	ipm	V	inches
10 GA	0.08"	0.16"	200	0.1	319	122	238	123	0.068"
3/16"	0.08"	0.16"	200	0.3	209	124	176	124	0.071"
1/4"	0.08"	0.16"	200	0.6	152	127	124	124	0.073"
3/8"	0.08"	0.16"	200	0.6	82	128	67	127	0.078"
1/2"	0.08"	0.2"	250	0.6	53	132	43	132	0.090"
5/8"	0.08"	0.2"	250	1.2	35	134	33	135	0.095"
3/4"	0.08"	0.24"	300	1.7	28	136	23	137	0.100"
7/8"	0.08"				21	139	18	140	0.115"
1"	0.08"				16	142	12	143	0,130"
1-1/8"	0.08"				12	144	9	146	0.140"
1-1/4"	0.08"				10	147	7	149	0.146"

PoWer CUT 155

I₂

85 A

CrNi

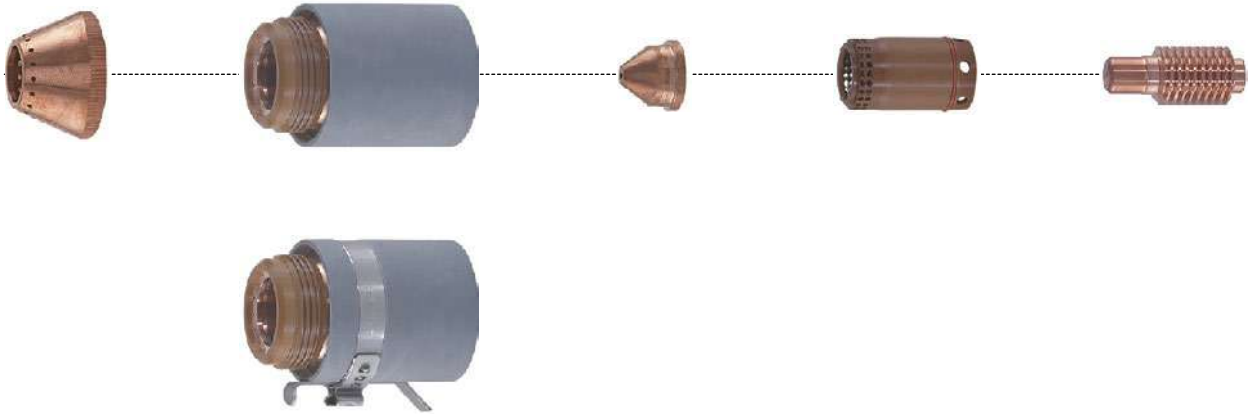

P 5,5 bar 80 psi	355 l/min 750 cfh	AIR AIR - Clean, dry, oil-free for ISO 8573-1 Class 1.2.2
----------------------------	----------------------	--

mm					PRODUCTION		QUALITY		
mm	mm	mm	%	sec	mm/min	V	mm/min	V	mm
3	2	4	200	0,2	8740	121	7120	123	1,6
4	2	4	200	0,3	7120	121	5790	123	1,7
6	2	4	200	0,6	4370	123	3510	123	1,8
8	2	4	200	0,6	2890	125	2320	125	1,9
10	2	5	250	0,6	1800	127	1470	128	2,1
12	2	5	250	0,8	1330	131	1040	132	2,3
16	2	5	250	1,2	720	135	660	136	2,4
20	2				540	138	450	139	2,5
25	2				350	142	280	144	2,6

in					PRODUCTION		QUALITY		
inches	inches	inches	%	sec	ipm	V	ipm	V	inches
10 GA	0.08"	0.16"	200	0.3	319	121	261	123	0.065"
3/16"	0.08"	0.16"	200	0.3	228	122	190	123	0.068"
1/4"	0.08"	0.16"	200	0.6	156	123	124	123	0.070"
3/8"	0.08"	0.16"	200	0.6	76	126	62	127	0.080"
1/2"	0.08"	0.20"	250	0.6	46	132	34	133	0.094"
5/8"	0.08"	0.20"	250	1.2	29	135	27	136	0.095"
3/4"	0.08"				23	137	19	138	0.096"
7/8"	0.08"				18	140	15	141	0.098"
1"	0.08"				13	142	10	144	0.100"

PoWer CUT 155







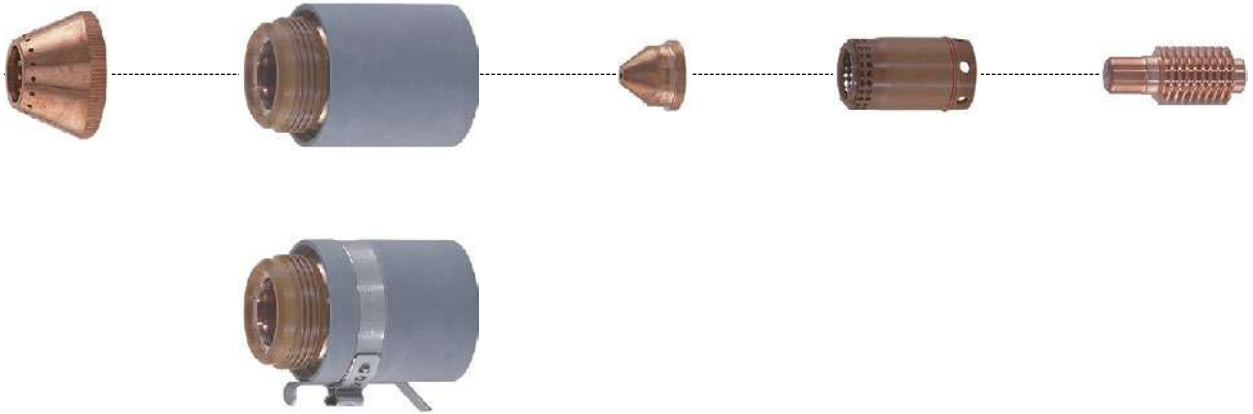

I₂

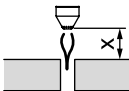

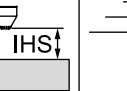
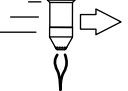

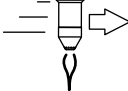

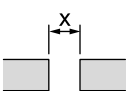

85 A

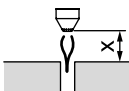
Al

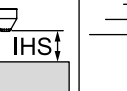
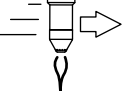

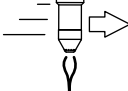
P 5,5 bar 80 psi	 355 l/min 750 cfh	AIR AIR - Clean, dry, oil-free for ISO 8573-1 Class 1.2.2
----------------------------	--	--

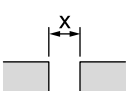
mm					PRODUCTION		QUALITY		
									
mm	mm	mm	%	sec	mm/min	V	mm/min	V	mm
3	2	4	200	0,2	8930	122	7600	123	1,8
4	2	4	200	0,3	7600	124	6170	124	1,9
6	2	4	200	0,6	4650	127	3610	127	2,0
8	2	4	200	0,6	3290	130	2510	131	2,0
10	2	5	250	0,6	2370	132	1820	133	2,1
12	2	5	250	0,8	1830	134	1370	135	2,2
16	2	5	250	1,2	1140	138	900	140	2,4
20	2				830	142	570	144	2,6
25	2				510	145	360	147	2,8

in					PRODUCTION		QUALITY		
									
inches	inches	inches	%	sec	ipm	V	ipm	V	inches
1/8"	0.08"	0.16"	200	0.3	342	122	285	123	0.075"
1/4"	0.08"	0.16"	200	0.6	163	128	124	128	0.080"
3/8"	0.08"	0.16"	200	0.6	99	132	76	133	0.085"
1/2"	0.08"	0.2"	250	0.6	65	134	48	136	0.090"
5/8"	0.08"	0.2"	250	1.2	46	138	36	140	0.095"
3/4"	0.08"				35	141	24	143	0.100"
7/8"	0.08"				28	143	19	145	0.105"
1"	0.08"				19	145	13	147	0.110"

PoWer CUT 155

I₂

65 A

Fe

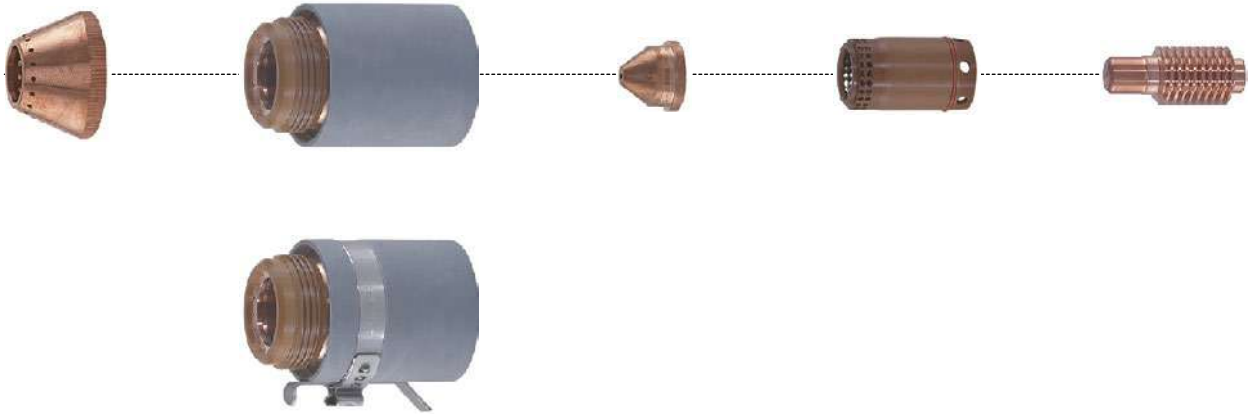

P 5,5 bar 80 psi	310 l/min 655 cfm	AIR AIR - Clean, dry, oil-free for ISO 8573-1 Class 1.2.2
----------------------------	------------------------------------	--

mm					PRODUCTION		QUALITY		
mm	mm	mm	%	sec	mm/min	V	mm/min	V	mm
2	1,5	3,8	250	0,15	6310	121	5330	120	1,5
3	1,5	3,8	250	0,2	5470	121	4630	121	1,6
4	1,5	3,8	250	0,4	4630	121	3930	121	1,7
6	1,5	3,8	250	0,5	2940	122	2530	123	1,8
8	1,5	3,8	250	0,6	2010	124	1870	125	1,9
10	1,5	4,5	300	0,7	1340	126	1360	127	2
12	1,5	4,5	300	1,1	1020	128	860	129	2,2
16	1,5	6	400	1,8	660	133	590	134	2,7
20	1,5				400	138	310	139	3
25	1,5				240	144	190	144	3,5

in					PRODUCTION		QUALITY		
inches	inches	inches	%	sec	ipm	V	ipm	V	inches
16 GA	0.06"	0.15"	250	0.15	264	120	223	120	0.061"
10 GA	0.06"	0.15"	250	0.2	201	121	171	121	0.066"
3/16"	0.06"	0.15"	250	0.45	156	121	134	122	0.068"
1/4"	0.06"	0.15"	250	0.5	104	122	90	123	0.071"
3/8"	0.06"	0.15"	250	0.7	55	126	58	127	0.08"
1/2"	0.06"	0.18"	300	1.1	36	129	27	130	0.089"
5/8"	0.06"	0.24"	400	1.7	27	133	20	134	0.106"
3/4"	0.06"				17	137	13	138	0.122"
7/8"	0.06"				13	141	10	141	0.136"
1"	0.06"				9	144	7	144	0.149"

PoWer CUT 155

I₂

65 A

CrNi

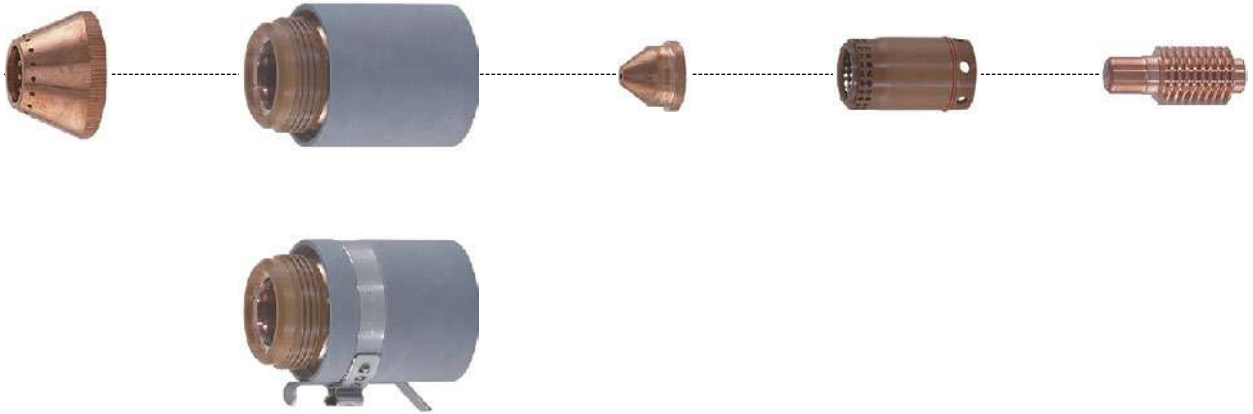

P 5,5 bar 80 psi	310 l/min 655 cfm	AIR AIR - Clean, dry, oil-free for ISO 8573-1 Class 1.2.2
----------------------------	------------------------------------	--

mm					PRODUCTION		QUALITY		
mm	mm	mm	%	sec	mm/min	V	mm/min	V	mm
2	1,5	3,8	250	0,15	8970	119	6660	117	1,3
3	1,5	3,8	250	0,2	7410	120	5500	118	1,4
4	1,5	3,8	250	0,4	5490	121	4350	120	1,6
6	1,5	3,8	250	0,5	2550	123	2040	123	1,7
8	1,5	3,8	250	0,6	1670	125	1350	125	1,8
10	1,5	4,5	300	0,7	1120	126	1000	128	1,9
12	1,5	4,5	300	1,1	830	128	640	131	2
16	1,5				450	134	410	135	2,1
20	1,5				310	139	280	139	2,2

in					PRODUCTION		QUALITY		
inches	inches	inches	%	sec	ipm	V	ipm	V	inches
16 GA	0.06"	0.15"	250	0.15	382	118	284	116	0.053"
10 GA	0.06"	0.15"	250	0.2	266	120	198	119	0.061"
3/16"	0.06"	0.15"	250	0.45	151	121	136	121	0.066"
1/4"	0.06"	0.15"	250	0.5	86	123	64	123	0.072"
3/8"	0.06"	0.15"	250	0.7	46	126	43	128	0.075"
1/2"	0.06"	0.18"	300	1.15	28	129	20	132	0.077"
5/8"	0.06"				18	134	17	135	0.084"
3/4"	0.06"				13	138	12	138	0.091"

PoWer CUT 155





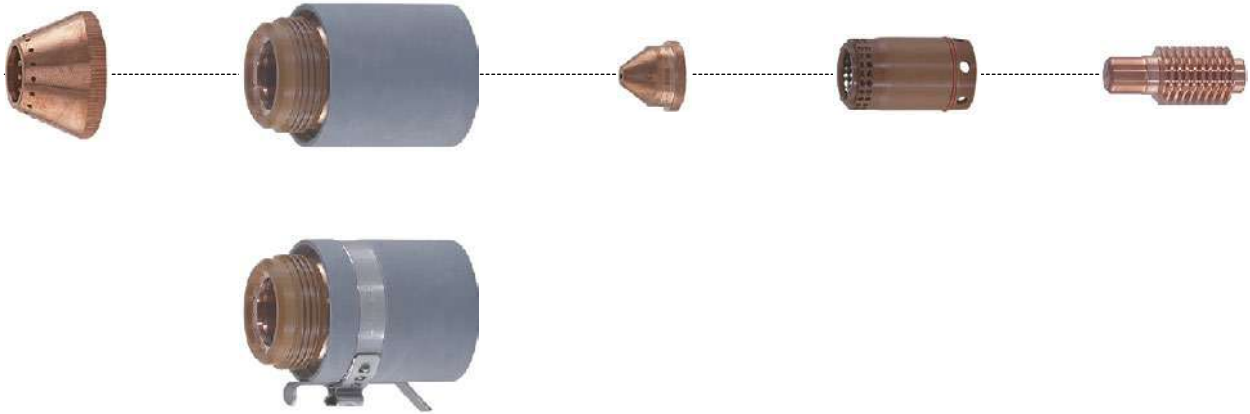

l₂



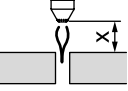
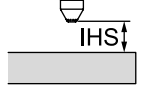
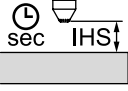
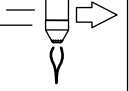

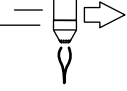

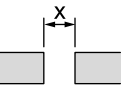

65 A

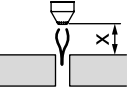
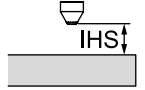
Al

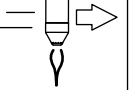

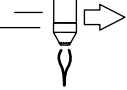
P 5,5 bar 80 psi	 310 l/min 655 cfm	AIR AIR - Clean, dry, oil-free for ISO 8573-1 Class 1.2.2
----------------------------	--	--

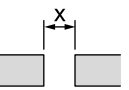
mm					PRODUCTION		QUALITY		
									
mm	mm	mm	%	sec	mm/min	V	mm/min	V	mm
2	1,5	3,8	250	0,15	9230	120	7020	121	1,9
3	1,5	3,8	250	0,2	7910	121	5900	123	1,9
4	1,5	3,8	250	0,4	6580	122	4780	124	1,9
6	1,5	3,8	250	0,5	3930	124	2560	127	2
8	1,5	3,8	250	0,6	2470	127	1810	131	2
10	1,5	4,5	300	0,7	1480	130	1380	134	2
12	1,5	4,5	300	1,1	1190	133	940	137	2,1
16	1,5				720	138	570	141	2,1
20	1,5				490	142	300	144	2,2

in					PRODUCTION		QUALITY		
									
inches	inches	inches	%	sec	ipm	V	ipm	V	inches
1/16"	0.06"	0.15"	250	0.1	385	120	295	121	0.075"
1/8"	0.06"	0.15"	250	0.2	302	121	225	123	0.075"
1/4"	0.06"	0.15"	250	0.6	136	124	85	128	0.076"
3/8"	0.06"	0.15"	250	0.75	61	129	58	133	0.078"
1/2"	0.06"	0.18"	300	1.15	43	134	31	138	0.08"
5/8"	0.06"				28	138	23	141	0.083"
3/4"	0.06"				21	141	14	143	0.086"

PoWer CUT 155





l₂

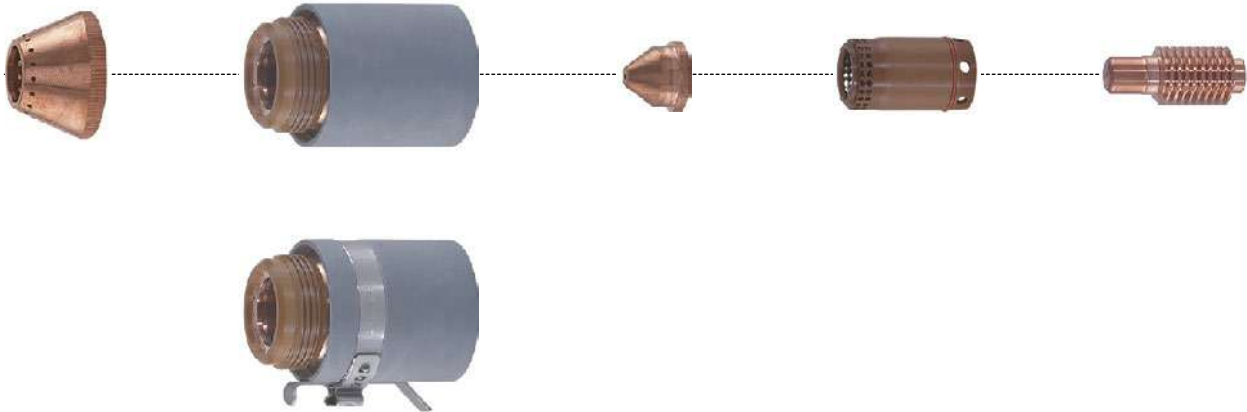

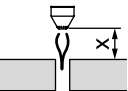
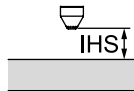
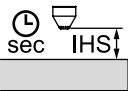
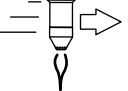

45 A

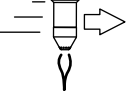
Fe

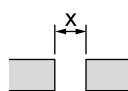

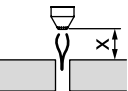
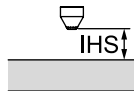
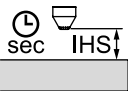
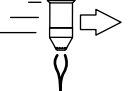
P 5,5 bar 80 psi	 275 l/min 580 cfh	AIR AIR - Clean, dry, oil-free for ISO 8573-1 Class 1.2.2
----------------------------	--	--

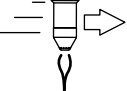
mm					PRODUCTION		QUALITY		
									
mm	mm	mm	%	sec	mm/min	V	mm/min	V	mm
0,5	0,5	2	400	0	11250	118	8000	116	1,3
1	0,5	2	400	0	9680	118	8000	117	1,4
1,5	0,5	2	400	0,15	9140	121	7230	121	1,4
2	1,5	3,8	250	0,3	6990	123	5900	126	1,5
3	1,5	3,8	250	0,35	4400	126	3350	127	1,5
4	1,5	3,8	250	0,4	3190	128	2020	128	1,5
6	1,5	3,8	250	0,55	1840	128	1130	130	1,6

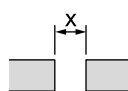
in					PRODUCTION		QUALITY		
									
inches	inches	inches	%	sec	ipm	V	ipm	V	inches
26 GA	0.02"	0.08"	400	0.0	450	118	315	116	0.049"
22 GA	0.02"	0.08"	400	0.0	405	118	315	116	0.051"
18 GA	0.02"	0.08"	400	0.1	360	118	315	117	0.053"
16 GA	0.02"	0.08"	400	0.15	360	121	282	121	0.057"
14 GA	0.06"	0.15"	250	0.2	288	123	243	126	0.061"
12 GA	0.06"	0.15"	250	0.3	194	125	166	127	0.061"
10 GA	0.06"	0.15"	250	0.4	147	128	90	128	0.062"
3/16"	0.06"	0.15"	250	0.5	97	128	66	129	0.064"
1/4"	0.06"	0.15"	250	0.6	65	128	38	130	0.065"

PoWer CUT 155

I₂

45 A

CrNi

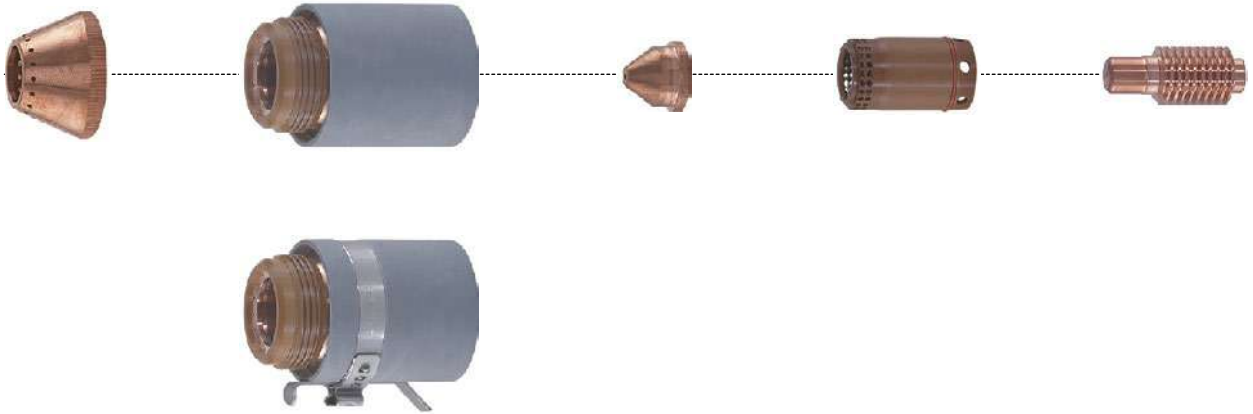

P 5,5 bar 80 psi	275 l/min 580 cfh	AIR AIR - Clean, dry, oil-free for ISO 8573-1 Class 1.2.2
----------------------------	----------------------	--

mm					PRODUCTION		QUALITY		
mm	mm	mm	%	sec	mm/min	V	mm/min	V	mm
0,5	0,5	2	400	0	11250	118	8000	111	1,3
1	0,5	2	400	0	9680	118	8000	111	1,3
1,5	0,5	2	400	0,15	9140	118	7040	115	1,4
2	1,5	3,8	250	0,3	7750	120	5480	120	1,4
3	1,5	3,8	250	0,35	3960	121	3220	121	1,5
4	1,5	3,8	250	0,4	2300	124	1960	124	1,6
6	1,5	3,8	250	0,55	910	130	870	130	1,7

in					PRODUCTION		QUALITY		
inches	inches	inches	%	sec	ipm	V	ipm	V	inches
26 GA	0.02"	0.08"	400	0.0	450	118	315	111	0.049"
22 GA	0.02"	0.08"	400	0.0	405	118	315	111	0.052"
18 GA	0.02"	0.08"	400	0.1	360	118	315	111	0.055"
16 GA	0.02"	0.08"	400	0.15	360	118	274	115	0.056"
14 GA	0.06"	0.15"	250	0.2	324	120	225	120	0.056"
12 GA	0.06"	0.15"	250	0.3	185	121	157	121	0.056"
10 GA	0.06"	0.15"	250	0.4	120	122	90	122	0.063"
3/16"	0.06"	0.15"	250	0.5	52	126	61	126	0.066"
1/4"	0.06"	0.15"	250	0.6	31	131	27	131	0.069"

PoWer CUT 155





l₂

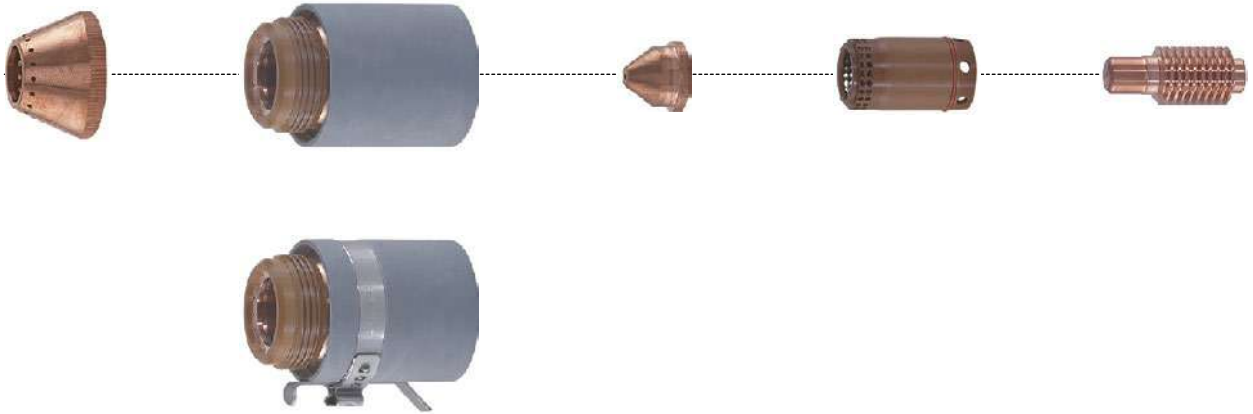



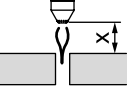
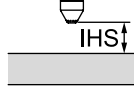
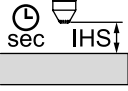
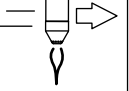

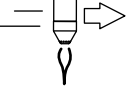
45 A

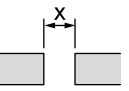
Al

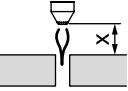
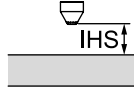

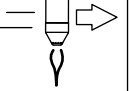
P 5,5 bar 80 psi	 275 l/min 580 cfh	AIR AIR - Clean, dry, oil-free for ISO 8573-1 Class 1.2.2
----------------------------	--	--

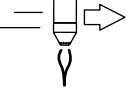
mm					PRODUCTION		QUALITY		
									
mm	mm	mm	%	sec	mm/min	V	mm/min	V	mm
1	1,5	3,8	250	0	9990	122	8230	124	1,5
2	1,5	3,8	250	0,15	8280	122	6720	123	1,5
3	1,5	3,8	250	0,2	5570	123	4200	123	1,6
4	1,5	3,8	250	0,35	4360	125	3330	127	1,7
6	1,5	3,8	250	0,55	2510	130	1560	133	1,8

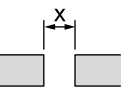
in					PRODUCTION		QUALITY		
									
inches	inches	inches	%	sec	ipm	V	ipm	V	inches
1/32"	0.06"	0.15"	250	0.0	405	122	324	124	0.055"
1/16"	0.06"	0.15"	250	0.1	360	122	324	124	0.058"
3/32"	0.06"	0.15"	250	0.2	295	122	209	122	0.060"
1/8"	0.06"	0.15"	250	0.4	201	123	159	124	0.063"
1/4"	0.06"	0.15"	250	0.5	86	131	49	134	0.071"

Maintenance

IMPORTANT: The machine is to undergo routine maintenance, as suggested by the manufacturer.

ATTENTION: Cut off the power supply to the equipment before effecting any internal inspection.

SPARE PARTS

Original spares have been specifically designed for our equipment.

The use of spares that are not original may cause variations in the performance and reduce the safety level of the equipment. We are not liable for damage due to use of spare parts that are not original.

THE EQUIPMENT

As these systems are completely static except for the fan that is, in any case, provided with self-lubricating bushes, only the following operations are necessary:

- Periodic removal of accumulations of dirt and dust inside the equipment using compressed air. Do not direct the air jet directly to electrical components that could be damaged.
- Periodical inspection for worn cables or loose connections that could cause overheating.
- Make sure the air circuit is completely free of any impurities and that the connections are tight and free of any leaks. In this regard, particular attention must be given to the solenoid valve and the air filter.
- Although the air filters do not have an automatic condensate drain, it is good practice to clean the air filter insert from time to time (Fig. R).

CARRYING OUT ROUTINE MAINTENANCE

WARNING: Disconnect the electricity supply before doing maintenance work. All tasks that call for the generator's cover to be removed, must be done by a qualified technician.

Each time you use the machine:

- Check the indication LEDs and fault icons. Correct any faulty condition.
- Check that the consumables are fitted correctly and are not worn.

Every 3 months:

- Inspect the power supply cable and plug. Replace if damaged.
- Check that the button is not damaged. Check that the torch grip is not cracked and there are no exposed wires. Replace any damaged component.
- Inspect the torch cable. Replace if damaged.

Every 6 months:

- Periodic removal of accumulations of dirt and dust inside the equipment using compressed air. Do not direct the air jet directly to electrical components that could be damaged.

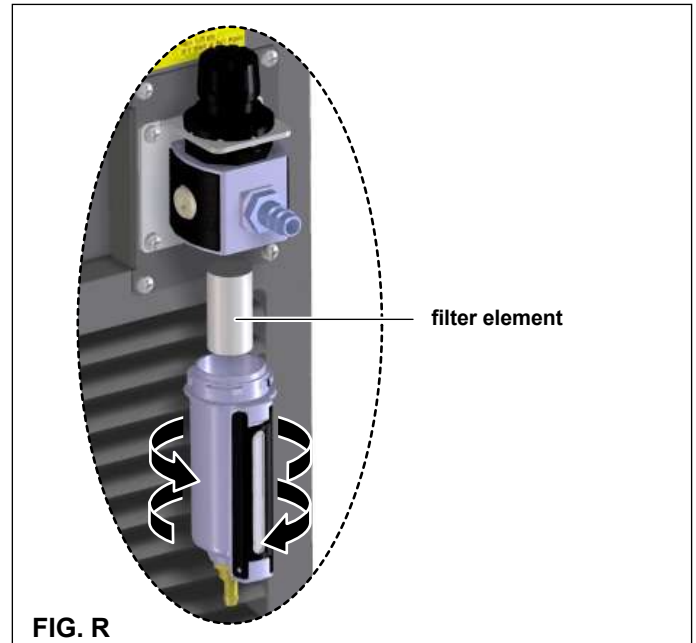
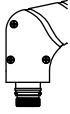
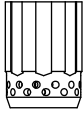

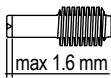
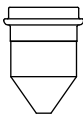

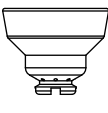

FIG. R

INSPECTION OF CONSUMABLES

Component	Inspection	Action
	Check that the surface is not damaged, worn or without lubrication.	If the O-ring is dry, lubricate it and the threads, with a thin layer of silicone lubricant. If the O-ring is worn or damaged, replace it.
	Check that the internal surface of the diffuser ring is not damaged or worn, and that the air holes are not obstructed.	Replace the diffuser ring if the surface is damaged or worn, or if the air holes are obstructed.
		Replace the electrode if the surface is worn or the depth of the crater is more than 1,6 mm.
	Roundness of the central hole. 	Replace the nozzle if the central hole is not round.
	Roundness of the central hole. Accumulation of debris in the space between the shield and the nozzle.	Replace the shield if the hole is oval. Remove the shield and clean off any debris.

WEAR OF CONSUMABLES



Possible problems and remedies

The power line is the cause of most problems. In case of breakdowns proceed as follows:

- 1) Check the line value of the voltage
- 2) Check that the power cable is perfectly fastened to the plug and mains switch
- 3) Make sure the fuses are not burnt or loose
- 4) Check the following for defects:
 - The switch that powers the machine
 - The wall socket for the plug
 - The equipment power switch

NOTE: Given the technical knowledge required for equipment repair, we recommend, in case of faults, that you contact qualified personnel or our technical support service.

Error condition

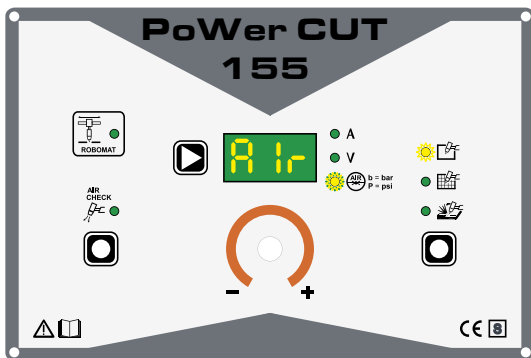

The equipment is protected against problems and if any arise the DISPLAY shows fixed or flashing (error code) messages (depending on the type of error) that serve to inform the operator that a fault has occurred in the equipment (see table 4). The table provides a simple summary of all the error conditions that may arise in the equipment and, where possible, what the operator must do to attempt to resolve the problem.

The table contains 2 types of errors:

- **Errors reset automatically:** once the alarm state has ended the equipment is ready to work again and the operator can begin cutting again!
- **Errors NOT reset automatically:** To eliminate the alarm states and reinstate correct functioning of the machine, the equipment must be switched off. When it is switched on again the machine will be working again and the operator can begin cutting again!
PLEASE NOTE: If when it switches on the error condition recurs, contact GeKaMac technical assistance immediately. All of this is necessary to allow our technical assistance department (**which must be contacted each time error messages appear on the equipment's operator interface**) to resolve problems more easily, as quickly as possible and thanks to the user's reports, also because, in the meantime the machine will not allow the operator to do their work.

Table 4

Display	Diagnosis
E00	TORCH BUTTON PUSHED This is activated of the cutting equipment is switched on with the torch button pushed. NON automatically reset error. Switch the machine off and check that the torch button is released before switching the equipment on.
E02	EXCESS VOLTAGE This is activated when the equipment's power supply voltage exceeds 480V . Error reset automatically. The equipment stops and is reset automatically as soon as the voltage is within the limits again.
E03	UNDER VOLTAGE This is activated when the equipment's power supply voltage is below 320 V . Error reset automatically. The equipment stops and is reset automatically as soon as the voltage is within the limits again.
E04	EXCESS CURRENT This is activated when the current on the primary IGBTs exceeds a predefined threshold. Error NOT reset automatically. Contact the technical assistance department immediately.
E08	CURRENT MEASUREMENT OFFSET This is activated when the offset on the current sensor is excessive. Error NOT reset automatically. Contact the technical assistance department immediately.
E10	SAFETY CONTACT OPEN (torch button) (Error only found on equipments with an optional "RoboMAT 1" analogue / digital robot interface). This is activated if the contacts between terminals 1 and 9 on the centralised adapter are opened, causing cutting to be interrupted, while the equipment is working normally or the next time it is switched on. NON automatically reset error. To correct this error the machine must be switched off and then switched on again. If, when switching on again, the error presents itself again, immediately contact the Technical Assistance Department.
E11	ROBOT READY SIGNAL MISSING (Error only found on equipments with an optional "RoboMAT 1" analogue / digital robot interface). This is activated if the welding robot connected to the equipment is not ready to work or if it is not working correctly. Automatic reset error.

Display	Diagnosis
E12	VOLTAGE READING ERROR This is activated when the cutting voltage is not read correctly. Check the wiring to the CN6 connector on the rack front board. Error reset automatically. The equipment stops and is reset automatically as soon as the voltage is within the limits again.
Air	NO AIR OR AIR PRESSURE INSUFFICIENT This is activated when there is no air in the equipment or when the air pressure measured is below a predefined threshold. This error is reset automatically when the torch button is released.
t°C	TRIP SWITCH Stoppage because the temperature is over the limits (thermostat tripped). Error reset automatically. The equipment stops and is reset automatically as soon as the temperature is within the limits again.

Main troubleshooting table

Defect	Cause	Remedy
Power switch (Pos. 8, Fig. A) on but DISPLAY off	<ul style="list-style-type: none"> Cutting equipment power supply cable not connected to the electricity mains or connected incorrectly or in a defective manner 	<ul style="list-style-type: none"> Connect the cutting equipment power supply cable to the mains power supply Check that the power supply cable is connected to the plug correctly and to the mains switch, and check that the mains fuses are not blown or loose
	<ul style="list-style-type: none"> Mains voltage incorrect 	<ul style="list-style-type: none"> Check that the voltage for the power supply to the cutting equipment corresponds to that for the actual mains power supply
	<ul style="list-style-type: none"> Some components in the cutting equipment are defective or malfunctioning 	<ul style="list-style-type: none"> Call in technical assistance
Lack of air with torch button pressed	<ul style="list-style-type: none"> Digital Interface Board or Power Source Board defective 	<ul style="list-style-type: none"> Check and, if necessary, replace both boards
	<ul style="list-style-type: none"> Defective solenoid valve 	<ul style="list-style-type: none"> Replace
Pilot arc does not go on when torch button is pressed	<ul style="list-style-type: none"> Electronic boards in the cutting equipment defective or malfunctioning 	<ul style="list-style-type: none"> Check and replace if necessary
	<ul style="list-style-type: none"> Electrode and torch nozzle worn 	<ul style="list-style-type: none"> Replace
	<ul style="list-style-type: none"> Torch button defective 	<ul style="list-style-type: none"> Replace
	<ul style="list-style-type: none"> Plasma torch connected incorrectly or defectively. 	<ul style="list-style-type: none"> Check the plasma torch's connection and replace it if necessary.
Arc goes out on contact with piece to be cut	<ul style="list-style-type: none"> Lack of connection of ground wire 	<ul style="list-style-type: none"> Connect ground wire

Changing the digital interface board

Proceed as follows:

- Remove the 4 screws that fix the membrane keyboard.
- Remove the ENCODER knob and the nut that fix the board to the membrane keyboard.
- Disconnect the board's electrical connectors.
- Unscrew the nuts and locking washers for the electronic board.
- Remove the electronic board, lifting it off its supports.
- To fit the new board, follow these instructions in reverse.

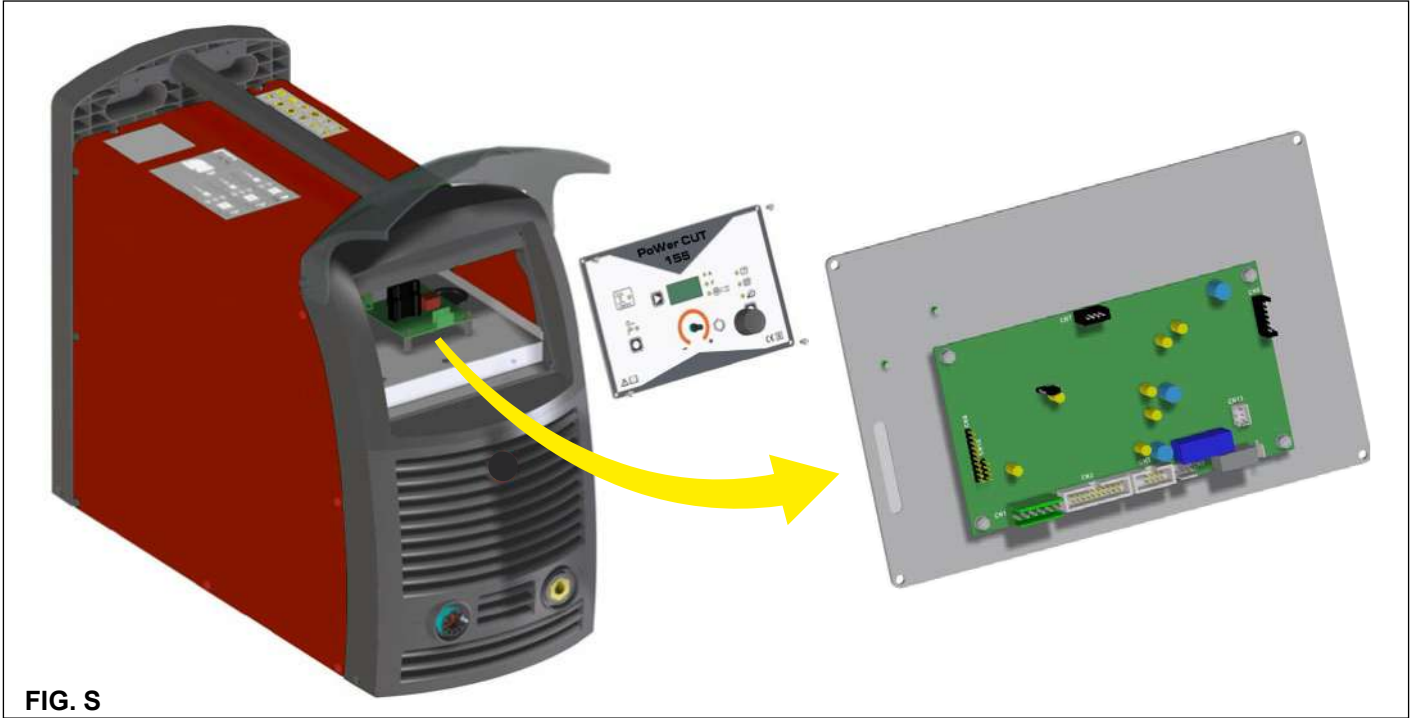







Common cutting defects

The table below provides an overview of common cut defects that can arise when using the machine, and explains how to resolve them.

Defect	Cause	Remedy
Insufficient penetration	<ul style="list-style-type: none"> • Cutting speed too high • Current too low 	<ul style="list-style-type: none"> • Reduce speed • Increase current
Main arc goes out	<ul style="list-style-type: none"> • Ground wire connected wrong • Cutting speed too slow • Excessive erosion of electrode 	<ul style="list-style-type: none"> • Check ground wire connection • Increase speed • Replace electrode
Excessive residues	<ul style="list-style-type: none"> • Cutting speed too slow • Electrode hole eroded 	<ul style="list-style-type: none"> • Increase speed • Replace electrode
Nozzle overheated or black	<ul style="list-style-type: none"> • Current too high • Gap between the nozzle and workpiece too small. • Air dirty • Excessive erosion of electrode 	<ul style="list-style-type: none"> • Reduce current • Increase space • Clean air filter • Replace electrode
Pilot arc intermittent or sparking	<ul style="list-style-type: none"> • Air dirty, greasy, wet • Pilot arc current too low • The air filter element is polluted, replace the element. • Check that there is no moisture in the air circuit. 	<ul style="list-style-type: none"> • Clean air filter • Check the equipment pilot arc circuit • Replace the element. • Install or repair the generator's air filter system.
The arc goes out but ignites again when the torch button is pushed again	<ul style="list-style-type: none"> • Consumables worn or damaged • Air dirty and polluted • Air pressure incorrect 	<ul style="list-style-type: none"> • Inspect consumable components and replace them • Replace the air filter element • Make sure the air pressure is at the correct level
The quality of the cut is poor	<ul style="list-style-type: none"> • Torch not used correctly • Consumables worn or damaged • Incorrect pressure or poor quality air • Cutting mode selector in incorrect position • Consumables not correct or fitted incorrectly 	<ul style="list-style-type: none"> • Check that the torch is used correctly • Check that the consumables are not worn, and replace if necessary • Check the air pressure and quality • Check that the cutting mode selector is in the correct position for the cutting operations. • Check that the correct consumables are fitted
The arc is not transferred to the plate	<ul style="list-style-type: none"> • Ground wire connected wrong • Earth clamp damaged • Piercing distance too great 	<ul style="list-style-type: none"> • Clean the contact area between the earth clamp and the plate, to ensure a good connection • Repair or replace the earth clamp • Reduce the distance

Meaning of graphic symbols on machine

	Main equipment switch
	Green LED, air test activated
	Green LED, solid material cutting mode
	Green LED, mesh material cutting mode
	Green gouging function LED
A	Green cutting current display LED
V	Green cutting voltage display LED
 b = bar P = psi	Green compressed air display in bar or psi LED
	Centralised plasma torch connection connector

	Positive earth cable connection polarity
	Green RoboMAT control display indicating LED
	Dangerous voltage
	Grounding protection
	Warning!
	Before using the equipment you should carefully read the instructions included in this manual
	Product suitable for free circulation in the European Community
	System for use in environments with increased risk of electrocution
	Special disposal

Wiring diagram

Key to the electrical diagram

AIR	Air inlet
CNC	CNC controller
CP	EMC condenser
CT	Plasma torch connector, machine side
D1-2-10-11	Secondary circuit diode module
DS	Transil diode dischargers
EL	Plasma torch electrode
EVG	Air solenoid valve
FE	EMC filter
FR	Regulator filter
FT	Toroidal ferrite
IL	Mains switch
IPS	Pressure sensor
L	Inductance
MIH	Primary upper IGBT module
MIL	Lower primary IGBT module
MV1-2	Fan motors
PM	Earth clamp
PT	Plasma torch button
Q1	Pilot arc IGBT circuit
RF	Front panel membrane keyboard
RP	Primary circuit rectifier
RSN	Secondary circuit snubber resistor
RV	Voltage divider resistor
S-AI	Robomat 1 interface
S-INT DIG	Rack panel digital board
S-INV	Primary Inverter PCB
S-IR	Robomat 1 interface isolation board
SL	Exhaust
S-PAD	Secondary board
S-PS	Power Source PCB
ST	Plasma torch safety sensor
S-TSF	Torch button PCB
TA	Hall effect transformer
THS	Secondary circuit thermostat
TIP	Plasma torch nozzle
TP	Main transformer
TPL	Plasma torch

Colour key

AN	Orange-Black
Ar	Orange
Az	Sky Blue
Bc	White
Bl	Blue
BN	White-Black
Gg	Grey
Gl	Yellow
GV	Yellow-Green
Mr	Brown
Nr	Black
RN	Red-Black
Ro	Pink
Rs	Red
Vd	Green
VI	Violet

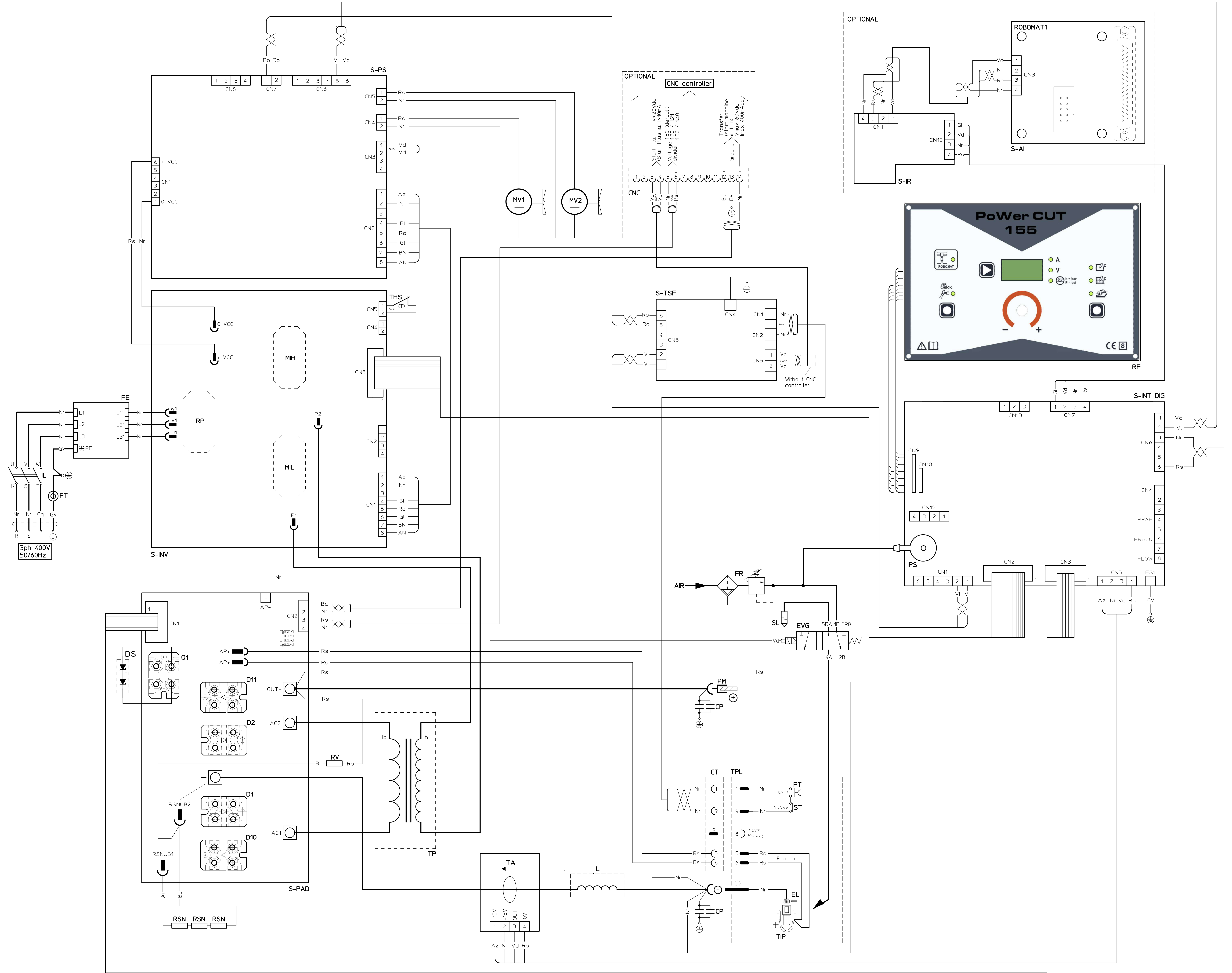

Power MAC 155

IT	<i>Lista ricambi</i>	LEGGERE ATTENTAMENTE
EN	<i>Spare parts list</i>	READ CAREFULLY
FR	<i>Liste pièce de rechange</i>	LIRE ATTENTIVEMENT
DE	<i>Ersatzteilliste</i>	SORGFÄLTIG LESEN
ES	<i>Lista repuestos</i>	LEER ATENTAMENTE
NL	<i>Onderdelenlijst</i>	EERST GOED DOORLEZEN
PT	<i>Lista de peças de substituição</i>	LER ATENTEMENTE
DA	<i>Liste over reservedele</i>	LÆS OMHYGGELIGT
SV	<i>Reservdelslista</i>	LÄS NOGAS
FI	<i>Varaosaluettelo</i>	LUE HUOLELLISESTI
N	<i>Reservedelliste</i>	LES NØYE
RU	<i>Список запасных частей</i>	ПЕРЕД НАЧАЛОМ РАБОТЫ ВНИМАТЕЛЬНО ПРОЧИТАТЕ ИНСТРУКЦИЮ



GeKaMac[®]



Gedik Welding Inc.

Ankara Caddesi No: 306 Şeyhli 34906 Pendik - İstanbul / Turkey

P. +90 216 378 50 00 • **F.** +90 216 378 20 44

www.gedikwelding.com



PoWeR CUT 155 Pos.	Descrizione	Description
1	Visiera rack frontale	Front rack transparent visor
2	Pannello frontale	Plastic front panel
3	Adesivo logo GeKaMac	GeKaMac logo sticker
4	Attacco dinse 50 mmq	Quick connection positive polarity
5	Cavo massa	Work cable and clamp
6	Attacco centralizzato plasma	Central connector for plasma torch
7	Contatto femmina per attacco centralizzato (N.10pz)	Female terminal for central connector (No.10 pcs)
8	Torcia Plasma taglio manuale PoWeR Cut 155 6 metri	Manual Plasma torch PoWeR Cut 155 6m
	Torcia Plasma taglio manuale PoWeR Cut 155 12 metri	Manual Plasma torch PoWeR Cut 155 12m
9	Torcia Plasma taglio automatico PoWeR Cut 155 6 metri	Machine Plasma torch PoWeR Cut 155 6m
	Torcia Plasma taglio automatico PoWeR Cut 155 12 metri	Machine Plasma torch PoWeR Cut 155 12m
10	Coperchio completo dei loghi PLASMATECH	Steel cover complete of logo PLASMATECH stickers
11	Adesivo logo PLASMATECH	Logo PLASMATECH sticker



PoWer CUT 155 Pos.	Descrizione	Description
12	Maniglia per il trasporto	Handle
13	Presse pannello femmina 14P CNC + terminali femmina	Panel CNC 14P female connector complete of female terminals
14	Contatto femmina per connettore CNC (N.10pz)	Female terminal for connector CNC (No.10 pcs)
15	Connettore volante maschio 14P CNC + terminali maschio	Mobile CNC 14P male connector complete of male terminals
16	Contatto maschio per connettore CNC (N.10pz)	Male terminal for connector CNC (No.10 pcs)
17	Filtro aria con regolatore pressione aria	Air filter with adjustment pressure
18	Attacco tubo 1/4 gas ingresso aria	Input air nipple 1/4 gas
19	Pannello posteriore	Plastic rear panel
20	Cavo linea	Main cable
21	Pressacavo completo	Main cable clamp
22	Manopola interruttore di linea	Knob for main switch
23	Adesivo interruttore 0-1	Main switch sticker 0-1

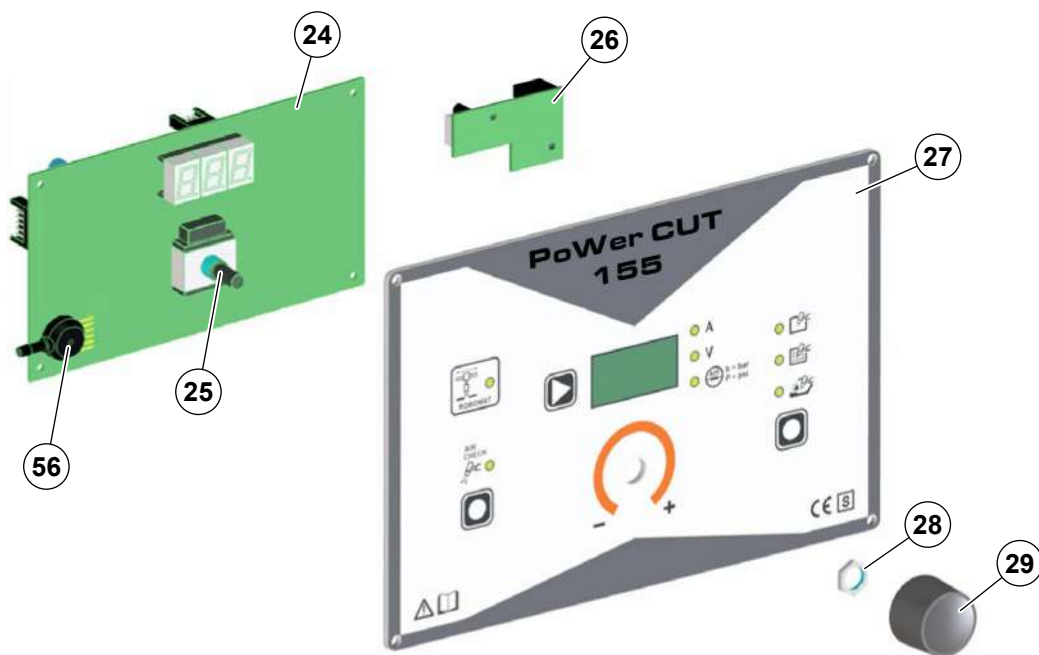

PoWer CUT 155 Pos.	Descrizione	Description
24	Scheda digitale pannello frontale completa di software	Digital rack pcb complete with software
25	Encoder	Encoder
26	Scheda isolamento interfaccia ROBOMAT	ROBOMAT interface insulation PCB
27	Tastiera a membrana	Membrane keyboard
28	Dado per encoder	Encoder nut
29	Manopola	Knob
56	Sensore di pressione aria	Air pressure sensor

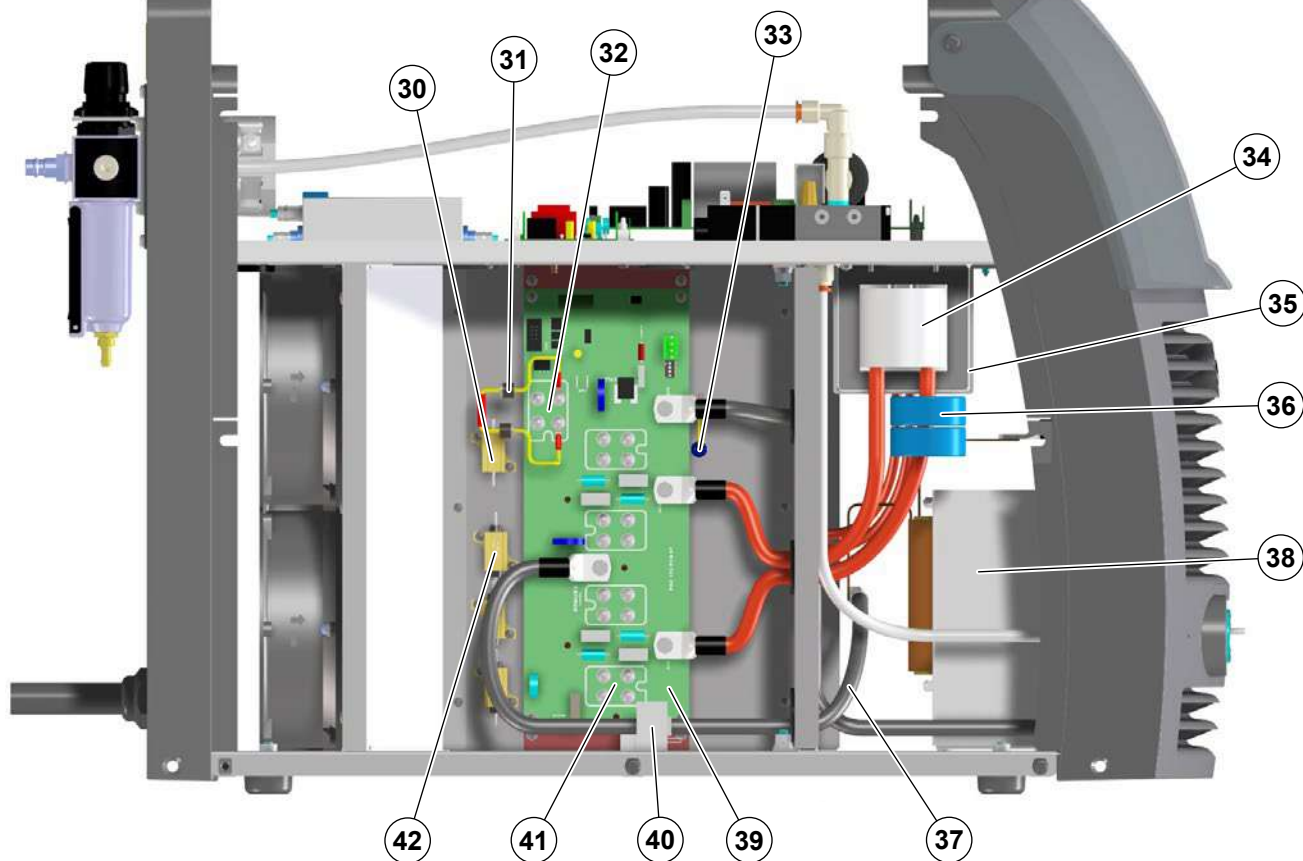

PoWer CUT 155 Pos.	Descrizione	Description
30	Resistore partitore di tensione	Voltage divider resistor
31	Assieme scaricatori di tensione	Transil assembly
32	IGBT comando arco pilota	Pilot arc IGBT module
33	Termostato	Thermostat
34	Trasformatore principale	Main transformer
35	Staffa fissaggio trasformatore di potenza	Main transformer clamp
36	Ferrite Ø46mm per trasformatore di potenza	Ferrite ring Ø46mm for main transformer
37	Cablaggio cavi di potenza	Power cables wiring
38	Induttore	Inductor
39	Scheda circuito secondario	Secondary circuit pcb
40	Trasformatore di corrente	Current hall transformer
41	Diodo secondario di potenza	Secondary power diode
42	Resistore snubber	Snubber resistor

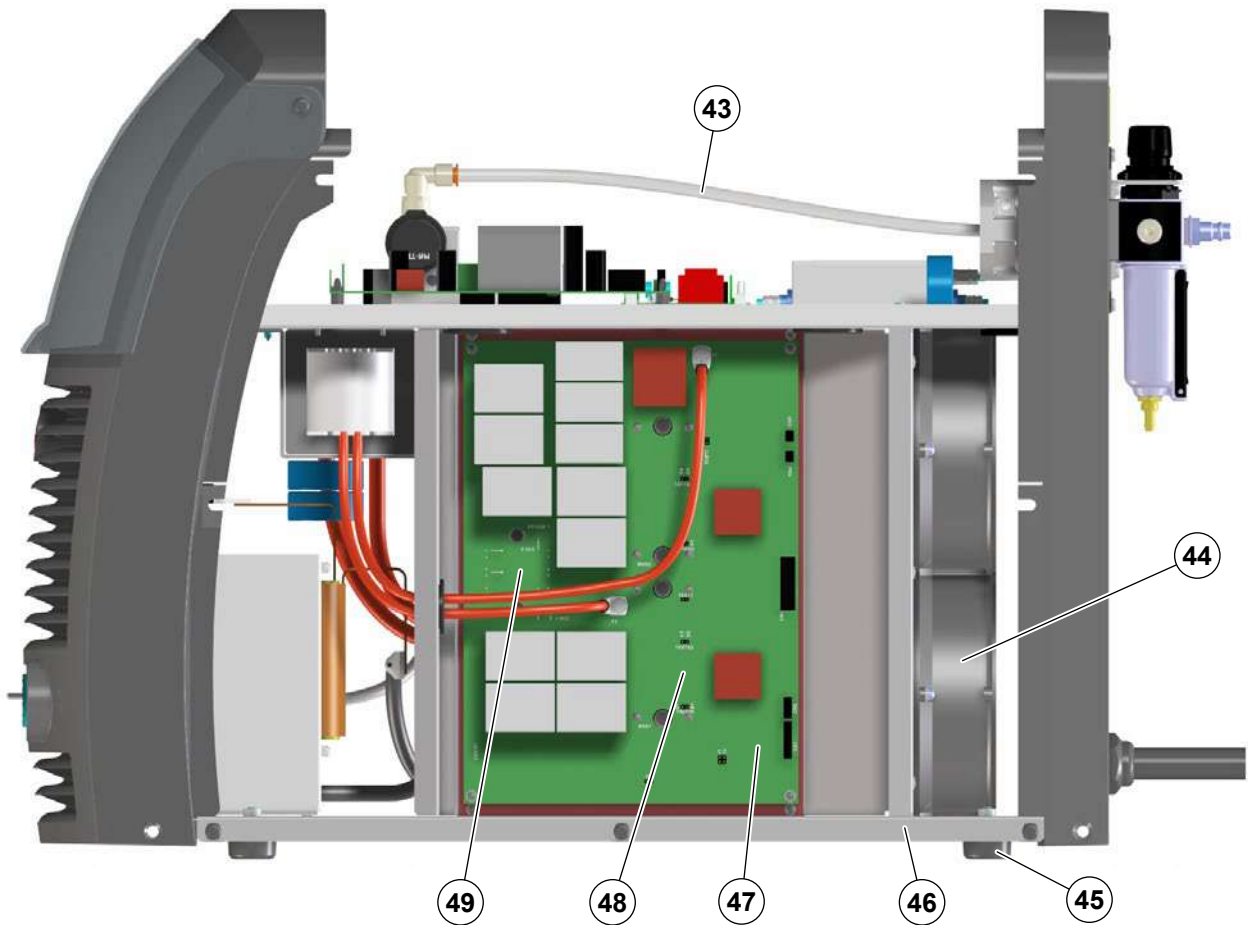

PoWer CUT 155 Pos.	Descrizione	Description
43	Tubo aria rilsan PA12 Ø6x8	Ø6x8 rilsan hose
44	Ventilatore	Fan
45	Piedino in gomma	Rubber foot
46	Basamento metallico	Steel base
47	Assieme scheda inverter circuito primario	Primary inverter assembly pcb
48	Modulo IGBT circuito primario	Primary circuit IGBT module
49	Ponte primario trifase	3ph primary power bridge

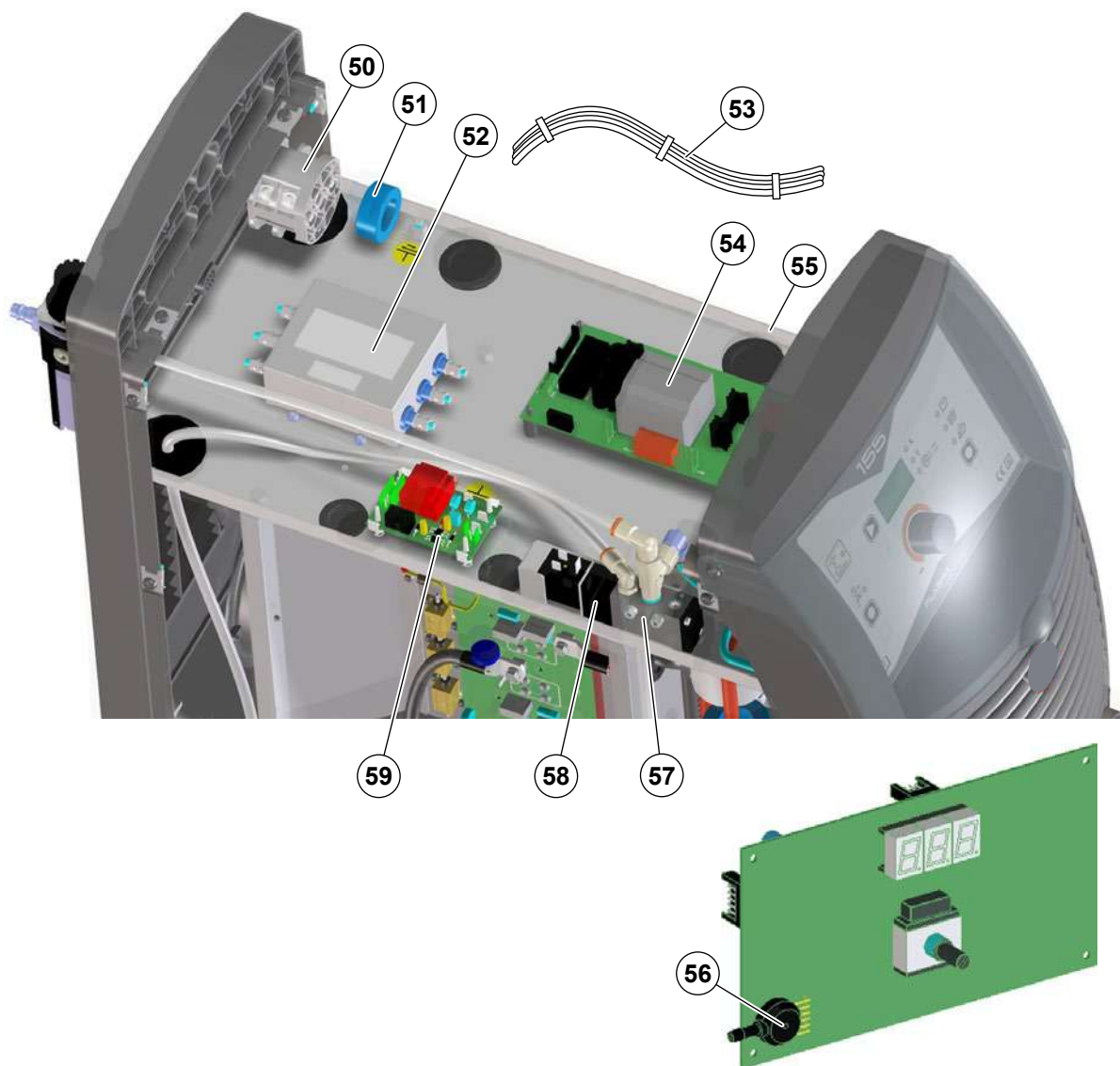

PoWer CUT 155 Pos.	Descrizione	Description
50	Interruttore principale	Main switch
51	Ferrite Ø40mm per il cavo linea	Ferrite Ø40mm for main cable
52	Filtro EMC	EMC filter
53	Cablaggio ausiliario	Auxiliary wiring
54	Scheda Power Source	Power Source pcb
55	Piastra metallica superiore	Steel upper plate
56	Sensore di pressione aria	Air pressure sensor
57	Staffa fissaggio elettrovalvola	Solenoid air valve steel bracket
58	Elettrovalvola aria	Air solenoid valve
59	Scheda filtro pulsante torcia	Torch switch filter pcb

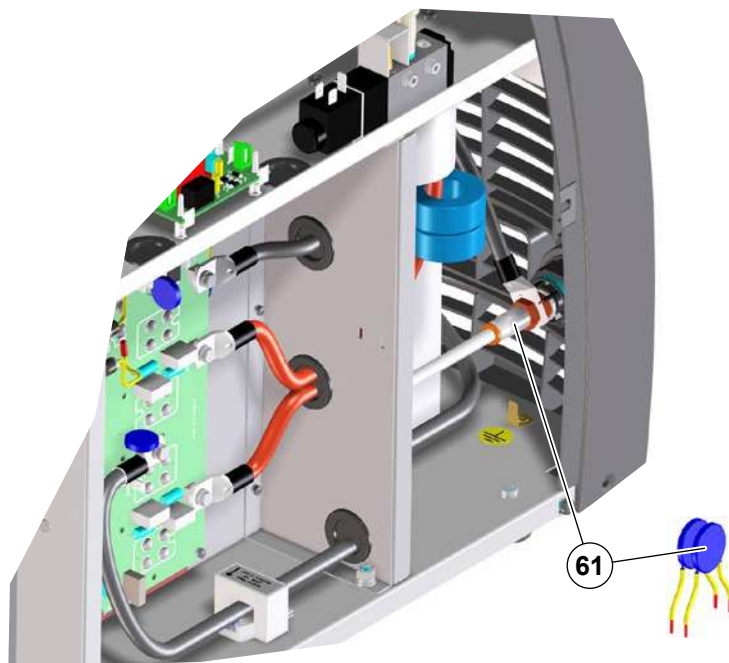
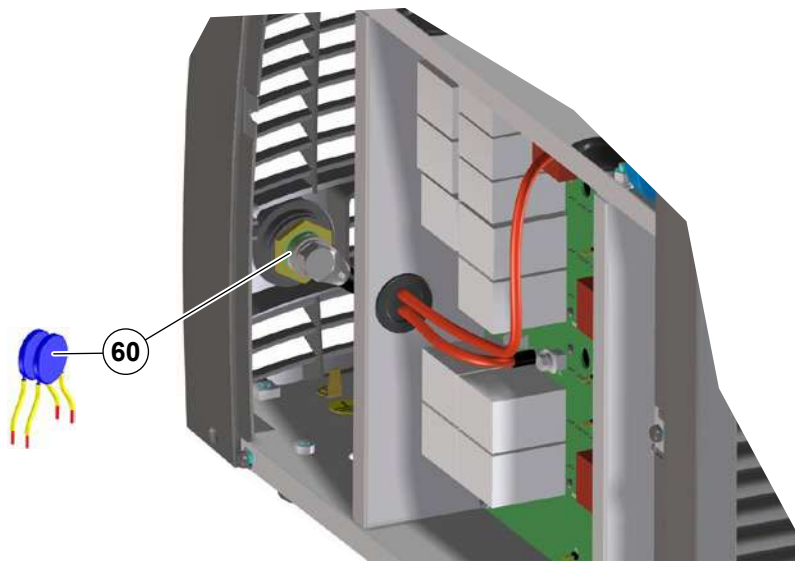

PoWer CUT 155 Pos.	Descrizione	Description
60	Condensatori Y2 EMC polo positivo	EMC Capacitor for positive pole
61	Condensatori Y2 EMC polo negativo	EMC Capacitor for negative pole

PoWer CUT 155

PoWer CUT 155

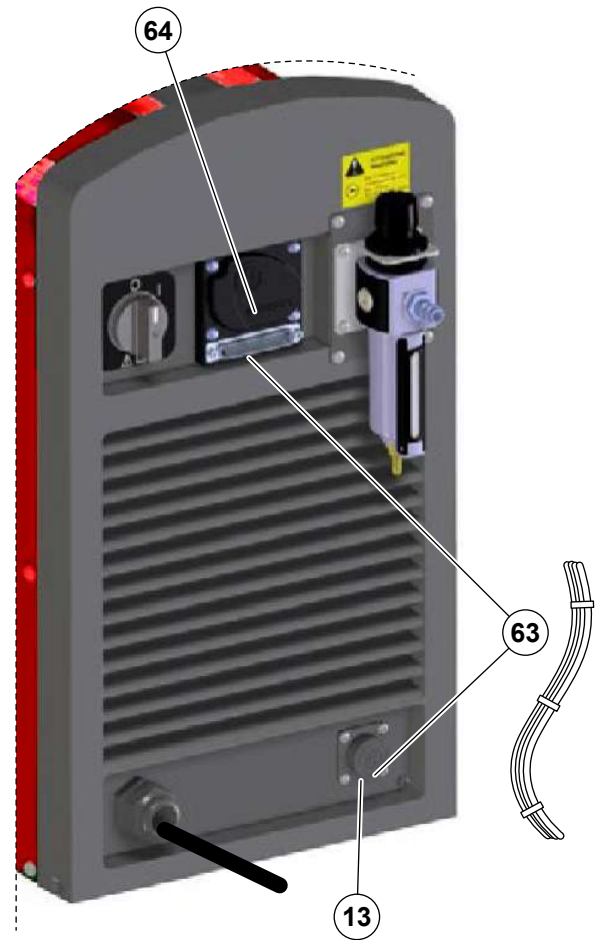

PoWer CUT 155 Pos.	Descrizione	Description
62	Cablaggio per CNC controller per versione PoWer CUT 155	CNC controller wiring for version PoWer CUT 155
63	Cablaggio per Robomat 1 controllo	Robomat 1 controller wiring
64	Interfaccia Robomat 1	Robomat 1 controller
13	Presse pannello femmina 14P CNC + terminali femmina	Panel CNC 14P female connector complete of female terminals

IT Ordinazione dei pezzi di ricambio

Per la richiesta di pezzi di ricambio indicare chiaramente:

- 1) Il numero di codice del particolare
- 2) Il tipo di impianto
- 3) La tensione e la frequenza che rileverete dalla targhetta dei dati posta sull'impianto
- 4) Il numero di matricola

ESEMPIO

N° 2 pezzi, codice n. 418874 - per l'impianto PoWer CUT 155 400 V - 50/60 Hz - Matricola n°

EN Ordering spare parts

To ask for spare parts clearly state:

- 1) The code number of the piece
- 2) The type of device
- 3) The voltage and frequency read on the rating plate
- 4) The serial number of the same

EXAMPLE

N. 2 pieces code n. 418874 - for PoWer CUT 155 - 400 V - 50/60 Hz - Serial number

FR Commande des pièces de rechange

Pour commander des pièces de rechange indiquer clairement:

- 1) Le numéro de code de la pièce
- 2) Le type d'installation
- 3) La tension et la fréquence que vous trouverez sur la petite plaque de données placée sur l'installation
- 4) Le numéro de matricule de la même

EXEMPLE

N. 2 pièces code 418874 - pour l'installation PoWer CUT 155 400 V - 50/60 Hz - Matr. Numéro

DE Bestellung Ersatzteile

Für die Anforderung von Ersatzteilen geben Sie bitte deutlich an:

- 1) Die Artikelnummer des Teiles
- 2) Den Anlagentyp
- 3) Die Spannung und Frequenz, die Sie auf dem Datenschild der Anlage finden
- 4) Die Seriennummer der Schweißmaschine

BEISPIEL

2 Stück Artikelnummer 418874 - für Anlage PoWer CUT 155 - 400 V - 50/60 Hz - Seriennummer

ES Pedido de las piezas de repuesto

Para pedir piezas de repuesto indiquen claramente:

- 1) El número de código del particular
- 2) El tipo de instalación
- 3) La tensión y la frecuencia que se obtien de la chapa datos colocada sobre la instalación
- 4) El número de matrícula de la soldadora misma

EJEMPLO

N. 2 piezas código 418874 - para instalación PoWer CUT 155 400 V - 50/60 Hz - Matrícula N.

NL Bestelling van reserveonderdelen

Voor het bestellen van onderdelen duidelijk aangeven:

- 1) Het codenummer van het onderdeel
- 2) Soort apparaat
- 3) Spanning en frequentie op het gegevensplaatje te vinden
- 4) Het serienummer van het lasapparaat

VOORBEELD

N. 2 stuks code 418874 - voor apparaat PoWer CUT 155 400 V 50/60 Hz - Serie Nummer

PT Requisição de peças sobressalentes

Ao pedir as peças de substituição indique claramente:

- 1) O número de código da peça
- 2) O tipo de equipamento
- 3) A tensão e a frequência indicadas na la placa de dados do equipamento
- 4) O número de matrícula da própria máquina de soldar

EXEMPLO

N° 2 peças código n. 418874 - para o equipamento PoWer CUT 155 - 400 V - 50/60 Hz
Matrícula n.

DA Bestilling af reservedele

For at bestille reservedele skal man nøjagtigt angive:

- 1) Reservedelens kodenummer
- 2) Anlæggets type
- 3) Spænding og frekvens, som står på anlæggets typeskilt
- 4) Selve svejsemaskinens registreringsnummer

EKSEMPEL

2 stk. nummer 418874 - til anlæg model PoWer CUT 155 - 400 V - 50/60 Hz
Registreringsnummer Nr.

SV Beställning af reservdelar

Vid förfrågan av reservdelar ange tydligt:

- 1) Detaljens kodnummer
- 2) Typ av apparat
- 3) Spänning och frekvens - den står bland tekniska data på apparatens märkplåt
- 4) Svetsens serienummer

EXEMPEL

2 st. detaljer kod 418874 - för apparat PoWer CUT 155 - 400 V 50/60 Hz - Serienummer

FI Varaosien tilaus

Tiedustellessanne varaosia, ilmoittakaa selvästi:

- 1) Osan koodinnumero
- 2) Laitteiston tyyppi
- 3) jännite ja taaiuus, jotka on ilmoitettu laitteistolle sijoitetusta tietokyltistä
- 4) Hitsauskoneen sarjanumero

ESIMERKKI

2 osaa, koodi 418874 - laitteistoon PoWer CUT 155 - 400 V-50/60 Hz - Sarjanumero

N Bestilling av reservedeler

Ved bestilling av reservedeler må du oppgi:

- 1) Delenes kodenummer
- 2) Type apparat
- 3) Apparatets spenning og frekvens som finnes på merkeplaten for data på apparatet
- 4) Sveiseapparatets serienummer

EKSEMPEL

2 stk. kode 418874 - for apparat PoWer CUT 155 - 400 V-50/60 Hz - Serienummer.....

RU Заказ запасных частей

Для запроса запасных частей укажите точно:

- 1) код запчасти,
- 2) модель машины,
- 3) напряжение и частоту, написанные на пластине,
- 4) ее серийный номер.

ПРИМЕР

2 шт., код № 418874
п - штук деталей, код 418874, для сварочной машины PoWer CUT 155 - 400 В - 50/60 Hz
Серийный номер



GeKaMac®



Gedik Welding Inc.

Ankara Caddesi No: 306 Şeyhli 34906 Pendik - İstanbul / Turkey

P. +90 216 378 50 00 • **F.** +90 216 378 20 44

www.gedikwelding.com